

LBV-40/LBV-75, 215 & 315

Installation, Operation & Maintenance Manual

Effluent & Sewage Vortex
Pump



IMPORTANT! - READ ALL INSTRUCTIONS IN THIS MANUAL
BEFORE OPERATING OR SERVICING A PUMP.

→PRIOR TO OPERATION

1. Be sure to provide an adequate grounding and install with leakage breaker to prevent the users from serious electric shock injury.
2. Make sure the voltage of the power supply are identical to the indications of the nameplate (label) on the pump. Do not plug into other voltage and phase than indicated on the nameplate.
3. Do not have a dry-run in the air, it will damage the pump.
4. Do not use the electrical cable to carry, lift or lower the pump. Please carry by the pump handle.
5. **Extension of power cable:**
When the power cable has to be extended, select the proper cable size within the allowable extension. If cable is extended too far, a drop in voltage may occur, which will stop the running of the motor and damage the pump.

DO NOT USE THE PUMP IN PONDS, SWIMMING POOLS, BATH TUBS, OR ANY OTHER AREA WHERE THERE ARE PEOPLE; SERIOUS ACCIDENTS CAN OCCUR.

→CARE UNDER OPERATION

1. When the pump stops suddenly (by the motor protection device): The motor protection device is built-in and shuts off the circuit automatically to prevent the motor from burning-out when the motor is overloaded due to clogging by foreign particles or when plugged-in to wrong power source (Voltage, Frequency, etc.). Should the pump stop suddenly, please check piping, pump itself, connection of electrical cable to power source, etc. The motor protector always automatically trips-off in a few seconds if there is any abnormality. Please resume the operation after clearing the trouble and leave the pump as it is.
2. Please consult your local dealer or company from which the pump was purchased if you are unable to solve the problem. Unauthorized personal is prohibited from disassembling or assembling the pump as it will probably result in inferiority in performance or damage to motor.

→CARE AFTER OPERATION

YOU DO NOT NEED TO TAKE ANY SPECIAL CARE ON THE PUMP AFTER OPERATION, HOWEVER, YOU MUST BE WARN OF THE FOLLOWINGS:

1. If a freezing temperature is predicted, lift up the pump from water and re-install it in dry condition.
2. If pump is left in the water for a long period of time without running, rust and other possible floating particles will accumulate in the pump, which will inevitably shorten the life of the pump. In this case, let the pump run in clean water and remove floating particles from inside the pump. Re-install it once dried.

→APPLICATIONS

THE MOST EFFICIENT, VERSATILE AND COST-EFFECTIVE PRODUCTS YOU'LL EVER USE!

- Draining from buildings and sanitary facilities.
- Water treatment process in sewage treatment yards.
- Sewage waste containing slender material and all wastewater removal.
- Draining other sewage water.



TO PREVENT SERIOUS ACCIDENTS, DISCONNECT THE POWER SUPPLY BEFORE INSPECTING THE PUMP

Table 1 Troubleshooting

CONDITIONS OF DISORDER	REASONS	COUNTERMEASURE
Pump fails to start.	No power is supplied. (Power outage)	Contact power company or an electrical repair shop.
	Open circuit or poor connection of the cabtyre cable.	Check if there is an open circuit in the cabtyre cable or wiring.
	Impeller is obstructed.	Inspect the pump and remove the obstruction.
Pump starts but stops immediately, causing the motor protector to actuate.	Impeller is obstructed	Inspect the pump and remove the obstruction.
	Voltage drop.	Correct the voltage to the rated voltage, or use an extension cable that meets the standard.
	A 50 Hz model is operated at 60 Hz.	Check the nameplate and replace the pump impeller.
	The strainer is obstructed, and the pump was operated dry for a long period.	Remove the obstruction.
	Motor sounds abnormal or will not run.	Repair the motor or replace with a new motor.
	The pump is picking up too much sediment.	Place a concrete block under the pump to prevent pump from picking up sediment.
The pump's head and pumping volume is lower.	The impeller is worn.	Replace impeller.
	The hose appears to be clogged.	Minimize the number of bends in the hose. (in an area with a large amount of debris, use the pump in a meshed basket.)
	The strainer is obstructed or buried.	Remove the obstruction. Place a concrete block under the pump to prevent pump from picking up sediment.
	The motor rotates in reverse.	Interchange the power supply terminal connection.
The pump generates noise or vibration.	The bearing of the motor may be damaged.	Replace the bearing. Contact an authorized service center or the dealer where you purchased the equipment.

→SERVICE AND WARRANTY

If you can not find the reasons of the problem, please consult the authorized local dealer or company from which the pump was purchased. The pump has a 1 year warranty from the invoice date. Invoice is required for any warranty work.

→TECHNICAL SPECIFICATIONS

MODELS	DISCHARGE	SOLID
LBV-40	2"	3/4"
LBV-75	2"	2"
LBV-215	2"	2"
LBV-315	3"	2"

Table 2 Specifications

MODEL	mm	in	Hp	Start	Run	Voltage/ Phase/HZ	mm	in	kg	lbs
LBV-40-50-0.6	50	2	1/2	13	5	115/1/60	19	3/4	16	34
LBV-40-50-0.6	50	2	1/2	5	2.64	220/1/60	19	3/4	16	34
LBV-40-50-0.6	50	2	1/2	7.6	1.59	208/1/60	19	3/4	16	34
LBV-40-50-0.6	50	2	1/2	7.5	1.8	230/1/60	19	3/4	16	34
LBV-40-50-0.6	50	2	1/2	3.5	0.7	460/1/60	19	3/4	16	34
LBV-40-50-0.6	50	2	1/2	3.9	0.90	480/1/60	19	3/4	16	34
LBV-40-50-0.6	50	2	1/2	2	0.57	575/1/60	19	3/4	16	34
LBV-75-1-1.1	50	2	1/2	30	2.64	115/1/60	50	2	21	46
LBV-75-1-1.1	50	2	1/2	15.4	1.59	220/1/60	50	2	21	46
LBV-75-1-1.1	50	2	1/2	15.8	1.8	208/3/60	50	2	21	46
LBV-75-1-1.1	50	2	1/2	15	0.7	230/3/60	50	2	21	46
LBV-75-1-1.1	50	2	1/2	7	0.90	460/3/60	50	2	21	46
LBV-75-1-1.1	50	2	1/2	7.8	1.70	480/3/60	50	2	21	46
LBV-75-1-1.1	50	2	1/2	4	1.14	575/3/60	50	2	21	46
LBV-215-2-1.3	50	2	1	36	10.58	220/1/60	50	2	25	55
LBV-215-2-1.3	50	2	1	24	6.35	208/3/60	50	2	25	55
LBV-215-2-1.3	50	2	1	22.5	5.9	230/3/60	50	2	25	55
LBV-215-2-1.3	50	2	1	12.1	2.87	460/3/60	50	2	25	55
LBV-215-2-1.3	50	2	1	13	2.68	480/3/60	50	2	25	55
LBV-215-2-1.3	50	2	1	9	2.30	575/3/60	50	2	25	55
LBV-315-2-1.3	80	3	1	36	10.58	220/1/60	50	2	25	55
LBV-315-2-1.3	80	3	1	24	6.35	208/3/60	50	2	25	55
LBV-315-2-1.3	80	3	1	22.5	5.9	230/3/60	50	2	25	55
LBV-315-2-1.3	80	3	1	12.1	2.87	460/3/60	50	2	25	55
LBV-315-2-1.3	80	3	1	13	2.68	480/3/60	50	2	25	55
LBV-315-2-1.3	80	3	1	9	2.30	575/3/60	50	2	25	55

LBV-40/LBV-75

Cut View

MULTIPURPOSE DRAINAGE PUMP

PARTS LIST

ITEM	DESCRIPTION	MATERIAL
1	Hose tail	Cast Iron 200
2	Cable gland	Fiber Plastic
4	Upper cover	SUS304
04A	Motor cover	
6	Pump casing	Cast Iron 200
7	Bearing Block	
9	Seal bracket	
10	Inlet plate	Cast Iron 200
11	Strainer	SUS304
12	Bottom Plate	
13	Shaft	SUS410
14	Rotor	Silicone Steel
16	Stator	Silicone Steel
20	Handle/Hanger	Steel
21	Motor frame	SUS304
22	Outer Case	SUS304
24	Shaft Sleeve	SUS304
25-25A	Bearing	
27	Protector	NBR
28	Gasket	NBR
30	Mechanical seal	CE/CA+SIC/SIC
32	Cable	
34	O'ring	
39	Impeller	Ductile Iron 45
54	Capacitor	
60	Flange	ABS
76	Bearing Block	Cast Iron 200
90	Rubber Liner	NBR

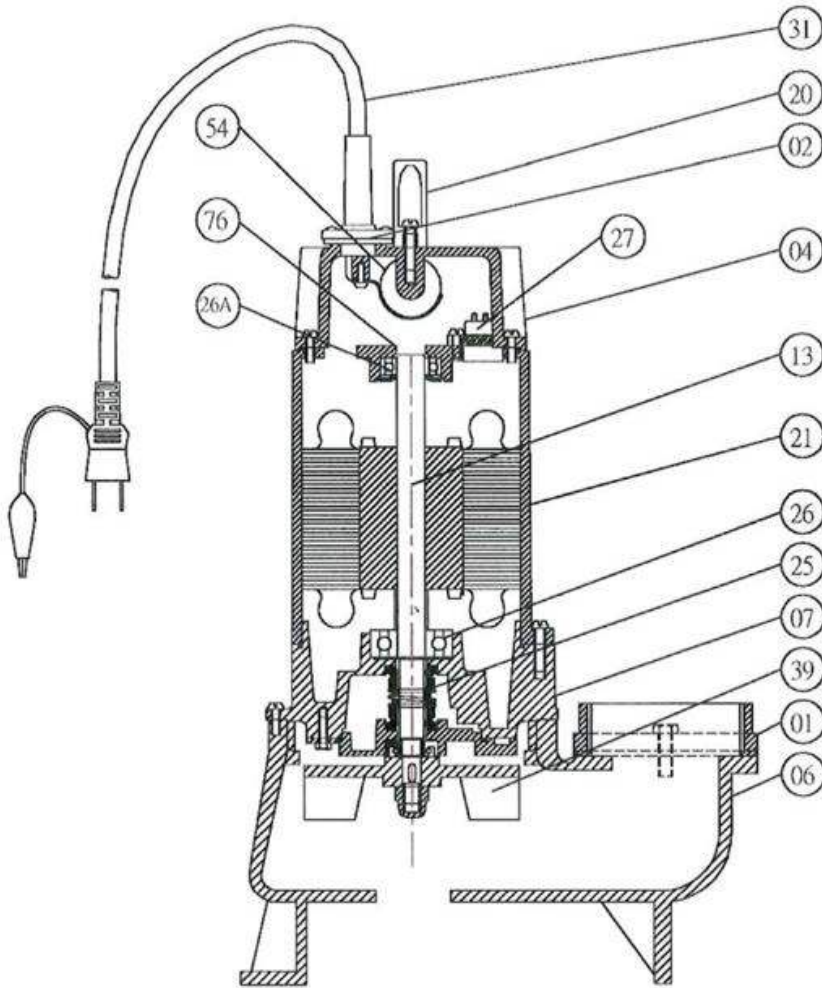

LBV-215/LBV-315

Cut View

MULTIPURPOSE DRAINAGE PUMP

PARTS LIST

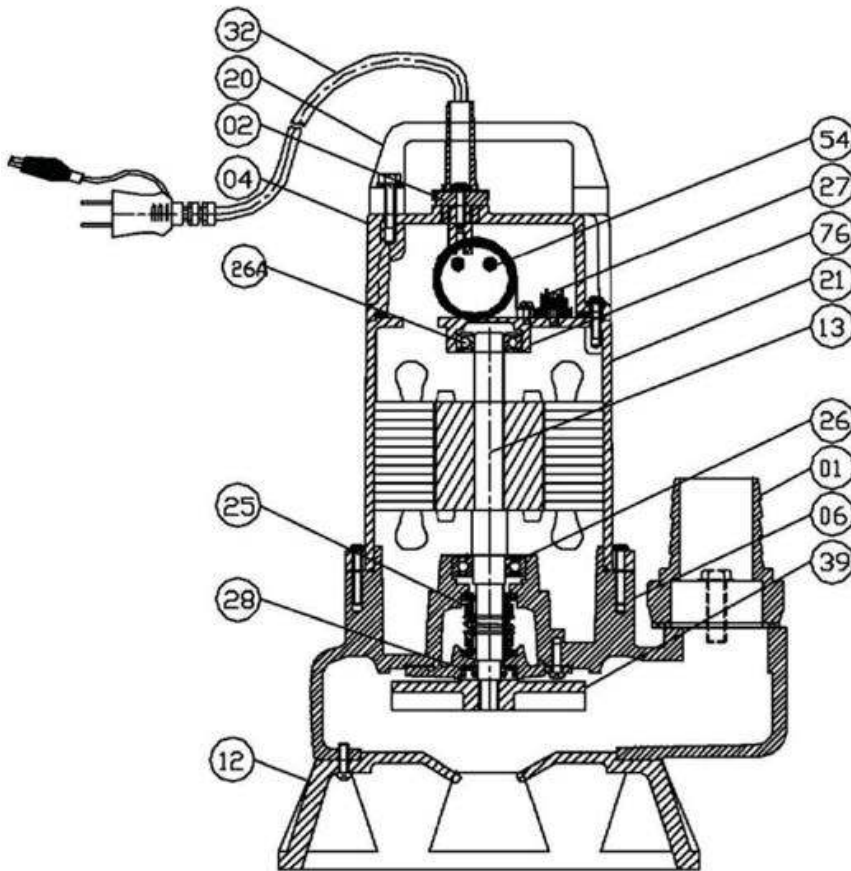

ITEM	DESCRIPTION	MATERIAL
1	Hose tail	Cast Iron 200
2	Cable gland	NBR
4	Upper cover	SUS304
04A	Motor cover	Cast Iron 200
6	Pump casing	Ductile Iron 50
7	Bearing Block	Cast Iron 200
9	Seal bracket	Cast Iron 200
10	Inlet plate	Cast Iron 200
11	Strainer	SUS304
12	Bottom Plate	Ductile Iron 50
13	Shaft	SUS410
14	Rotor	Silicone Steel
16	Stator	Silicone Steel
20	Handle/Hanger	Steel
21	Motor frame	Cast Iron 250
22	Outer Case	SUS304
24	Shaft Sleeve	SUS410
25-25A	Bearing	
27	Protector	
28	O'ring	NBR
28	Gasket	NBR
30	Mechanical seal	CE/CA+SIC/SIC
32	Cable	
34	O'ring	SC40
39	Impeller	High Chrome Steel
54	Capacitor	
60	Flange	
76	Bearing Block	Cast Iron 200
90	Rubber Liner	NBR

NOTICE TO INSTALLING CONTRACTOR

Instructions must remain with installation.

→GENERAL INFORMATION

These models are complete systems used in sewage or dewatering installations with side outlet flanged pumps. They can be used in basins of 1 Oft depth (for deeper depths, consult factory). The guide rail systems are particularly useful when the liquid level is above the pump discharge pump. The systems feature easy automatic engagement and disengagement for removing the pump for service or repair without draining the basin.

→GENERAL CONSTRUCTION

A flanged discharge elbow base is supplied with the rail system. The elbow base has casted mounting pins which supports the lower rail guides. The elbow base, mounting plate, as well as the upper guide rail bracket are made of durable dast 30 cast iron that is epoxy coated. All models require the use of 1" schedule 40 (galvanized steel or stainless steel) pipe for guide rails. Pipe is furnished by the installer.

→LIFTING CABLE

The pump is equipped with lifting lugs that are an integral part of the motor housing or cover for lifting. A permanently attached chain or cable (purchased separately), should be used to aid in pump installation and removal. It is not necessary to use a separate pull chain on the mounting plate which is bolted to the pump discharge flange.

→UPPER GUIDE RAIL SUPPORT BRACKET

As mentioned above, all the rail systems utilize 1" standard pipe for the guide rails. The upper guide support rail bracket is to be mounted to the basin cover frame, as per the discretion of the installer.

→APPLICATIONS

THE MOST EFFICIENT, VERSATILE AND COST-EFFECTIVE PRODUCTS YOU'LL EVER USE!

- Water intake or discharge for agriculture.
- Draining of basement or sumps pits.

→INSTALLING RAIL SYSTEM PARTS (CONCRETE BASIN)

Discharge Elbow Base and Guide Rails

1. Lower the elbow base into the basin.
2. Position the elbow base by dropping a plumb line from the center of the guide rail pins located on the upper guide rail bracket to the center of guide rail pins protruding from the elbow base. Level the elbow base flange in two directions 90° to each other. Mark the outline of the base and bolt holes/slots on the concrete basin floor.
3. Move the base aside to allow for installation of 1" mounting bolts (not included & method of installation to be determined by installer). Secure base with mounting bolts.
4. Cut the 1" pipe guide rails (supplied by others) to the proper length and install them between the pins of the upper guide rail bracket and the pins on the elbow base. It is recommended that the guide rails are to be 1" schedule 40, galvanized or stainless steel pipe.

→INSTALLING RAIL SYSTEM PARTS (FIBERGLASS BASIN)

Discharge Elbow Base, Discharge Piping and Guide Rails

1. Determine proper length required for discharge piping.
2. Connect discharge piping to elbow base.
3. Lower the discharge piping/elbow base assembly into the basin.
4. Position the elbow base by dropping a plumb line from the center of the guide rail pins located on the upper guide rail bracket to the center of guide rail pins protruding from the elbow base. Level the elbow base flange in two directions 90° to each other.
5. Cut the 1" pipe guide rails (supplied by others) to the proper length and install them between the pins of the upper guide rail bracket and the pins on the elbow base. It is recommended that the guide rails are to be 1" schedule 40, galvanized or stainless steel pipe.

→ATTACHING MOUNTING PLATE TO PUMP

1. Determine if mounting adapter flange (included) is required for proper assembly.
2. Position mounting plate against pump discharge flange or (if required) sandwich mounting adapter flange between mounting plate and pump discharge flange.
3. Secure mounting plate to pump with screws and washers. Tighten securely.

→ LIFTING CABLE

The pump is equipped with lifting lugs that are an integral part of the motor housing or cover for lifting. A permanently attached chain or cable (purchased separately), should be used to aid in pump installation and removal. It is not necessary to use a separate pull chain on the mounting plate which is bolted to the pump discharge flange.

→ INSTALLING PUMP AND DISCONNECT

Position pump so the guide rails are captured by the mounting plate. Slowly lower the pump down the guide rails to the base.

If the pump is supported from beneath with concrete blocks or extended legs on the pump base, make certain the mounting plate is sufficiently compressed for sealing. The cantilevered weight of the pump is required for compressing and sealing the machined faces between the mounting plate the elbow base.

After lowering the pump down the guide rail, secure the upper end of the lifting cable where convenient, to prevent the cable from falling into the basin.

