

# SERIES 840SC

1/3 - 75 HP @ 1750 & 3500 RPM

## Installation, Operation & Maintenance Manual

Vertical In-Line  
Centrifugal Split Coupling



**IMPORTANT!** - READ ALL INSTRUCTIONS IN THIS MANUAL  
BEFORE OPERATING OR SERVICING A PUMP.



# CAUTION!

**Do not run pump dry, seal damage may occur, inspect pump seal regularly for leaks, replace as required.**

For lubrication requirements, consult service instructions, failure to follow instructions could result in injury or property damage.

- Coupler alignment is required!
- Level & grout pump before use!
- Check alignment before grouting, after system is filled, after servicing pump, and as required.
- Consult the service instructions for details.

Failure to follow these instructions could result in injury or property damage. Failure to follow this instruction may void the warranty of the unit.

### VERTICAL IN LINE PUMPS

FLO FAB In Line pumps are designed to be mounted vertically in the pipe line with the motor above the pump. Center line suction and discharge keep weight evenly balanced and directly down upon the piping. No flexible connections to take up pipe misalignment are necessary since pump is not permanently connected to anything but the piping and is free to move with the expansion and contraction of the piping system. Support of the piping at the pump may be made by two pipe hangers, floor saddles or floor flanges, placed on line close to the pump.

Selection of the actual type of support is determined after consideration of the structural characteristics at the location of the pump, size and weight of both the piping and the pump, expansion and contraction of the piping, etc. In other words, the same criteria and formula for selecting piping supports are used with the additional consideration that the weight of the pump is concentrated at one point in the piping. Otherwise, piping recommendations are the same as for other types of pumps. For example, gate valves should be installed at both the pump suction and discharge to permit servicing of the pump without draining the entire system. If vertical inline pumps are mounted in a straight horizontal run of piping, then the weight of the piping and pump system is generally supported by pipe supports, or spring hangers, and experience has shown that no additional pump support, vibration or noise isolation devices are required.

### CAUTION

- INSTALL VERTICAL INLINE PUMPS WITH MOTOR IN VERTICAL POSITION.
- MAKE CERTAIN THE SPACE ABOVE THE PUMP IS SUFFICIENT TO GIVE CLEARANCE FOR LIFTING THE PUMP ASSEMBLY FROM THE CASING. ALSO THE SPACE AROUND THE PUMP SHOULD BE LARGE ENOUGH FOR GENERAL ACCESSIBILITY AND VENTILATION.
- SUPPORT PUMP ONLY BY PIPING.
- MANUALLY VENT ALL AIR FROM CASING.
- MAKE SURE SUCTION VALVE IS WIDE OPEN BEFORE STARTING MOTOR.
- CHECK MOTOR ROTATION (CLOCKWISE LOOKING DOWN FROM TOP OF MOTOR).

### FLOOR MOUNTED TYPE VERTICAL IN LINE PUMPS

Larger FloFab vertical in line pumps and split coupled pumps have supporting floor plate under the casing. These pumps are to be floor mounted but otherwise piped-up the same way as shown. Although vertical in line pumps are vibration free, it is recommended for floor mounted pumping units to provide isolation between pedestal block and foundation structure and flexible members in pipes adjacent to pump.

Typically, the natural rubber pad would have a hardness in the range of 50 durometer, a thickness of 0.375 inches and up, depending on the loading and site conditions, and be designed for a maximum deflection of 8 mm. This arrangement has been used, successfully, for many years on all types of flooring systems. The recommended arrangement diminishes noise transmission and provides adequate vibration isolation in the horizontal and vertical planes.

### WHEN INSTALLING MFV VALVE

If you are using the MFV valves as a balancing valve, you must have these installed 10 times the pipe size diameter to obtain any type of accuracy. If these are only to be used as a throttling, check, and shut off valve, then 5 times the pipe diameter after the pump discharge is acceptable.

If the system balancing at less than 50% stem rise and this is the primary balance valve, ASHREA Standard 90.1 and FloFab recommend trimming the impeller to the necessary system design flow. This will reduce electrical energy consumption and comply with the National Energy Building Code Standard. To avoid noise problems and possible damage to the valve, do not exceed 25 feet of pressure drop across the MFV valve.

**INSTALL LIKE THIS**

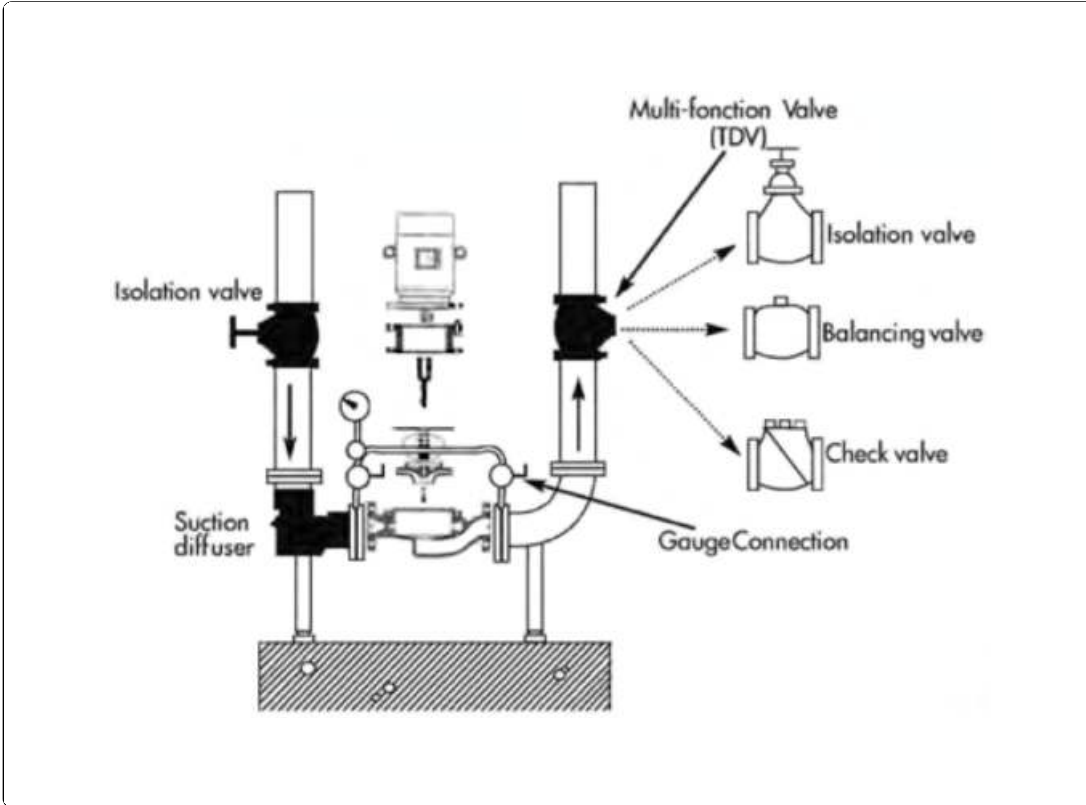

**DO NOT INSTALL LIKE THIS**

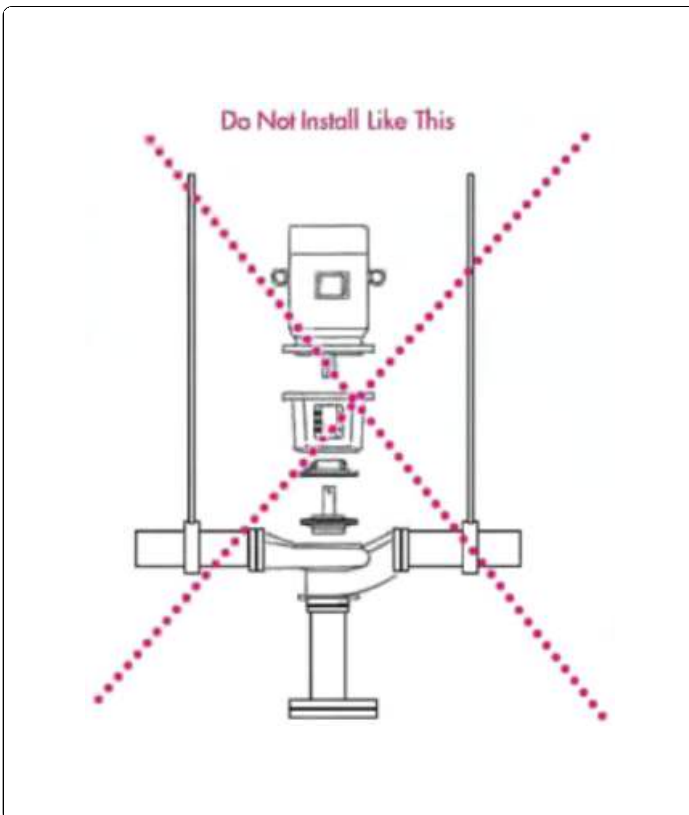

### → STARTING OF ELECTRIC MOTOR DRIVEN PUMPS

#### 1. BEFORE CONNECTING MOTOR AND STARTER TO THE LINE:

- Check wiring information available inside the conduit box.
- Check voltage and frequency of power supply with what's shown on motor nameplate.
- Check current rating of overload relays and fuses against nameplate full load current value.

#### 2. CHECK LUBRICATION AND POCKING (SEE MAINTENANCE).

#### 3. CHECK IF ROTOR IS FREE TO TURN.

It must be possible to revolve the rotor by hand. If the rotor drags even slightly, do not operate until the cause of trouble is located and corrected.

#### 4. FOR UNIT WITH FLUID DRIVE, REFER TO THE MAINTENANCE INSTRUCTIONS OF AUID DRIVES.

#### 5. IF UNIT IS FOR HIGH TEMPERATURE APPLICATION, REFER TO OPERATING INSTRUCTIONS FOR HIGH TEMPERATURE PUMPS.

#### 6. PRIME THE PUMP.

A pump is primed when casing and suction line are filled with liquid and when all the air contained in the pump has been allowed to escape. If pump is to operate under suction lift without foot valve, priming is done by pumping air out by means of an ejector, on exhauster or a vacuum pump.

#### 7. CHECK DIRECTION OF DRIVER ROTATION

Proper direction is indicated by arrow on pump casing.

#### 8. CHECK ELECTRIC MOTOR

Check electric motor current as soon as motor is started to verify whether or not the mechanical load applied corresponds to the motor rating. The continuous full load current value should be within the electric motor nameplate rating with service factor taken into account.

#### CAUTION

MAKE SURE THE GATE VALVE ON PUMP SUCTION IS FULLY OPEN AS THROTILING ON SUCTION SIDE IS HARMFUL TO THE PUMP.

MAKE SURE PUMP WILL NOT RUN DRY. MOST CENTRIFUGAL PUMPS HAVE CLOSE CLEARANCES AND CANNOT RUN DRY WITHOUT SERIOUS DAMAGE RESULTING.

#### LONG TERM STORAGE

Here are some general suggestions for long term storage. The applicability of all, or some, of these suggestions depends on several factors such as type of equipment, length of storage, and condition of the environment.

#### GENERAL CARE

Drain the casing completely and dry it thoroughly, including its bearing housing and stuffing box, or seal chamber. Apply a coat of soluble rust preventive solution both internally and externally.

Cover all openings. Flanged openings (such as suction and discharge nozzles) should be covered with blind flanges with elastomer gasket. Threaded openings should be covered with steel plugs or caps.

Protect the bearing housing from moisture by placing bags of vapor phase inhibitor crystals around the housing.

Cover the equipment with industrial strength plastic, preferably transparent to allow its visual inspection, including its nameplate, without uncovering the unit.

Store the unit in its normal position in a dry place.

**Inspect the unit PERIODICALLY and turn the shaft a few times at least 1/4 turn. Turning the shaft prevents pitting of finished surfaces. The extra 1/4 turn is to displace the sag and prevent the shaft from developing a permanent bow.**

This needs to be done at least **ONCE A MONTH**.



A systematic inspection made at regular intervals, giving special attention to the following, will ensure years of trouble-free operation.

### →GENERAL CARE

- 1 . KEEP UNIT CLEAN.**
- 2. AVOID EXCESSIVE BELT TENSION.**
- 3. PROVIDE THE MOTOR WITH ADEQUATE OVERLOAD PROTECTION.**
- 4. KEEP FLYING CHIPS OR OTHER LOOSE PARTICLES AWAY FROM THE VENTILATING OPENINGS OF THE MOTOR.**
- 5. AVOID OPERATING THE UNIT IN OVERHEATED SURROUNDINGS.**
- 6. GUARD THREE PHASE MOTOR AGAINST SINGLE PHASING WHICH IS FREQUENTLY ACCOMPANIED BY AN UNUSUAL HUMMING SOUND, A DROP IN SPEED, AND BY EXCESSIVE HEATING.**
- 7. USE THERMOMETERS WHEN CHECKING TEMPERATURES.**
- 8. IF PUMP IS STANDING IDLE IN FREEZING WEATHER, PUMP CASING AND PIPING SHOULD BE DRAINED.**

### →BEARINGS

#### **1. LIFE LUBRICATED BEARINGS**

Life lubricated bearings are heavy duty permanently lubricated, sealed type and require no maintenance.

#### **2. GREASE LUBRICATED BEARINGS**

Grease lubricated bearings require very little attention. More trouble can be caused by overcharging than by undercharging with grease. Approximately every month, depending on service, inject a small quantity of grease (Esso Andok No. 280 or equal) into bearing container after removing the grease outlet plug so that old grease is flushed out and bearing is not overfilled.

### **MECHANICAL SHAFT SEAL LIMITATIONS**

Standard FloFab pumps are equipped with mechanical seals. Standard mechanical seals have Ni-resist seat, carbon washer and Viton below. Maximum recommended operating temperatures and pressures are shown below.

MOTOR HP & SPEED	SUCTION PRESSURE (PSIG)	MAX TEMPERATURE (°F)
Up to 10HP 1750 RPM	60 85 125	250 225 160
15-50HP 1750 RPM	50 60 100	250 225 160
Up to 15HP 3500 RPM	20 125	180 120
20-60HP 3500 RPM	15 115	180 120

### →CAUTION

→ **A MECHANICAL SEAL IS A PRECISION PRODUCT. HANDLE IT WITH CARE. SPECIAL CARE MUST BE TAKEN WITH THE SEALING WASHER AND SEAT. DO NOT LET THEM DROP AND TAKE PARTICULAR CARE NOT TO SCRATCH THE LAPPED FACES.**

→ **NEVER RUN SEALS DRY.**

→ **FOLLOW SEAL MANUFACTURER'S INSTRUCTIONS.**

**1 . PROTECT PUMP WITH A SUITABLE STRAINER.**

**2. NEVER PUMP A LIQUID FOR WHICH THE PUMP WAS NOT DESIGNED (CHECK WITH YOUR FLOFAB REPRESENTATIVE)**

**3. KEEP THE RIGHT AMOUNT OF THE RIGHT LUBRICANT IN BEARINGS AT ALL TIMES, FOLLOWING LUBRICATION INSTRUCTIONS.**

**4. CHECK PERIODICALLY PUMP AND MOTOR ALIGNMENT.**

**5. ANY DOWN SLOPING TOWARDS THE PUMP IN SUCTION PIPING SHOULD BE CORRECTED.**

**6. SEE THAT PIPING PUTS NO STRAIN ON PUMP CASING.**

**7. NEVER ALLOW PUMP TO RUN DRY.**

**8. EXAMINE WEARING RINGS AT REGULAR INTERVALS.**

**9. IF SHAFT SLEEVES ARE BADLY SCORED, REPLACE THEM IMMEDIATELY.**

**10. IF THE LIQUID BEING PUMPED CONTAINS GRIT, O SEPARATE SOURCE OF SEALING LIQUID SHOULD BE USED.**

**11. A ROUTINE MAINTENANCE SCHEDULE SHOULD BE SET-UP TO ENSURE AN OPTIMUM INSPECTION AND SERVICE OPERATION IN ORDER TO GET THE BEST SERVICE OUT OF YOUR PUMPING EQUIPMENT.**

### **VERTICAL INLINE PUMP MAINTENANCE & SERVICE**

Type V, VL, RI, SC pumps are built to operate without periodic maintenance with the exception of lubrication motor bearings with silicone grease such as Dow-Corning 44, Keystone #78 or Supermill ASU 06752 grease every 3 months. Good operational life will depend upon proper pump selection, installation and continuous wafer lubrication of the mechanical seals. The air vent plug must always be loosened to thoroughly vent casing before start-up and fo insure water lubrication of mechanical seals.

Impurities in the system will shorten the operational life of mechanical seals due to the generally abrasive characteristics of these impurities. Most common is black iron oxide which is highly magnetic and has a tendency to form hard coating on all surfaces in contact with water. Water treatment is also an important factor in seal life. It is recommended that the chromate content in water be limited to 250 ppm.

### **RENEWAL PARTS**

The service for which centrifugal pump is used will determine, to a great extent, the minimum number of spore ports that should be carried in stock at the installation site. The minimum for any centrifugal pump should include:

- ONE SET OF WEARING RINGS
- ONE SET OF SHAFT SLEEVES (OR A SHAFT IF NO SLEEVES ARE USED)
- ONE SET OF BEARINGS
- SUFFICIENT STOCK OF SPARE MECHANICAL SEAL
- MATERIAL FOR GASKET

When ordering spare or repair parts, always give pump serial number and full description of part(s) required.

### **WARRANTY**

FloFab pumps are guaranteed against defective workmanship and material for a period of twelve months from date of shipment from manufacturing plant. Should the pump fail within this warranty period, our responsibility is limited to the repair or replacement of defective parts, provided such ore returned to our Plant, transportation prepaid. We do not accept liability for damage or break-down from causes beyond our control, or the result of reasonable wear nor for repair mode, or attempted to be made without prior sanction, nor for any consequential damage resulting from the failure of a pump. The customer will assume all labour charges incurred in making the replacement or adjustment of the parts.



**PLEASE NOTE THAT THERE IS NO GUARANTEE ON MECHANICAL SHAFT SEALS.**

**TROUBLE CHART**

SYMPTOMS	POSSIBLE CAUSES
Pump does not deliver water	1, 2, 3, 4, 6, 11, 14, 16, 17, 22, 23
Insufficient capacity delivered	2, 3, 4, 5, 6, 7, 8, 9, 10, 11, 14, 17, 20, 22, 23, 29, 30, 31
Insufficient pressure developed	5, 14, 16, 18, 19, 20, 23, 24, 26, 27, 29, 33, 34, 37
Pump loses prime after starting	2, 3, 5, 6, 7, 8, 11, 12, 13
Pump requires excessive power	15, 16, 18, 19, 20, 23, 24, 26, 27, 29, 33, 34, 37
Stuffing box leaks excessively	24, 26, 32, 33, 34, 35, 36, 38, 39, 40
Packing has short life	12, 13, 24, 26, 28, 32, 33, 34, 35, 36, 37, 38, 39, 40
Pump vibrates or is noisy	2, 3, 4, 9, 10, 11, 21, 23, 24, 25, 26, 27, 28, 30, 35, 36, 41, 42, 43, 44, 45, 46, 47
Bearings have short life	24, 26, 27, 28, 35, 36, 41, 42, 43, 44, 45, 46, 47
Pump overheats and seizes	1, 4, 21, 22, 24, 27, 28, 35, 36, 41

It is unnecessary to disconnect piping or casing to service these pumps. All service and maintenance can be performed by removing pump assembly from casing.

**1 . DISCONNECT WIRING TO THE MOTOR.**

**2. REMOVE CASING BOLTS, CONNECTING CASING AND SPACER AND ENTIRE PUMP ASSEMBLY CAN BE WITHDRAWN MOTOR AS SHOWN.**

**3. REMOVE IMPELLER BOLT BY TURNING IT COUNTER CLOCKWISE. PULL OFF THE IMPELLER BY WEDGING AROUND ITS PERIPHERY AND SLIP OUT THE IMPELLER KEY FROM ITS SHAFT GROOVE.**

**4. SLIDE SPRING LOADED CARBON ROTATING FACE OFF IMPELLER SHAFT.**

**5. REMOVE BOLTS CONNECTION MOTOR TO ADAPTER TO LIFT OFF ADAPTER.**

**6. IF WEAR RINGS ARE TO BE REPLACED, SPLIT WITH COLD CHISEL TO REMOVE FROM ITS RECESS. REPLACE RING OFFER SMOOTHING AND LIGHTLY LUBRICATING RECESS AND TOP THE NEW RING WITH A LEAD HAMMER.**

**7. IF MOTOR SHAFT SLEEVE IS TO BE REPLACED, IT IS IMPORTANT THAT NO PRESSURE BE PLACED UPON THE MOTOR BEARINGS. ALL FORCE MUST BE DIRECTLY AGAINST THE MOTOR SHAFT ONLY AS THE SLEEVE IS REMOVED AND REPLACED.**

**FIGURE V - TYPE 840SC**

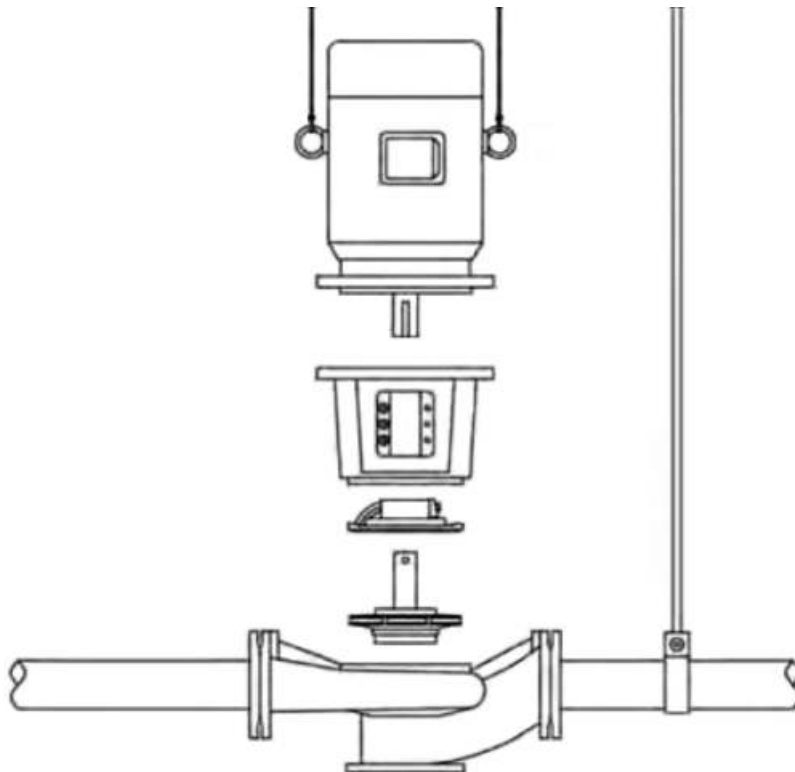

**RE-ASSEMBLY**

- 1 . CLEAN SEAL RECESS OF ADOPTER. LIGHTLY LUBRICATE SEAT RING AND PRESS STATIONARY SEAL ASSEMBLY AND ADOPTER.**
- 2. BOLT MOTOR TO ADAPTER. USE CAUTION NOT TO BUMP THE MOTOR SHAFT AGAINST THE MECHANICAL SEAL.**
- 3. REPLACE IMPELLER KEY IN SHAFT GROOVE. SLIP ON SPRING LOADED CARBON SEAL AND IMPELLER ON SHAFT.**
- 4. REPLACE IMPELLER CAP SCREW AND TIGHTEN BY TURNING CLOCKWISE.**
- 5. REMOVE OLD CASING AND ADAPTER GASKET AND CLEAN OFF ANY PIECES THAT MAY HAVE BROKEN OFF ON THESE COSTINGS. PUT NEW GASKET ON ADAPTER.**
- 6. LOWER PUMP ASSEMBLY INTO CASING. USE CAUTION TO PROPERLY ALIGN IMPELLER INTO CASING SO THAT IT WILL NOT BE DAMAGED. TIGHTEN-UP CAP SCREWS EVENLY AND IN ROTATION.**
- 7. FILL PUMP CASING WITH WATER AND VENT ALL AIR BY LOOSENING AIR VENT PLUG.**
- 8. RE-CONNECT MOTOR WIRING. CHECK MOTOR ROTATION TO INSURE PROPER OPERATION.**

**DISASSEMBLY**

Regular service and maintenance of Type SC Pumps can be performed without removing motor or rotating assembly.

- 1 . LOOSEN CAPSCREWS IN EACH COUPLING HUB AND REMOVE CENTER PART OF SPACER COUPLING.**
- 2. REMOVE BOTTOM HUB OF COUPLING, THEN BEARING LOCK NUT, WASHER AND NUTS AND LIFT OUT BEARING HOUSING.**
- 3. REMOVE SEAL GLAND. WHEN MECHANICAL SEAL ONLY NEEDS TO BE REMOVED, COMPLETE BEARING AND SEAL GLAND CAN BE REMOVED AS A CARTRIDGE BY TOKING OUT THE TWO NUTS GOING THROUGH THE GLAND.**
- 4. REMOVE LOWER BEARING CONTAINER FOR INSPECTION (IF NECESSARY) BY TOKING OFF THE BOLTS.**
- 5. ON MAJOR OVERHAULS WHERE ROTATING ASSEMBLY MUST BE REMOVED, DISCONNECT COUPLING, REMOVE MOTOR COUPLING AND CARTRIDGE BEARING HOUSING AND SEAL GLAND. REMOVE MOTOR STEEL AND TOP COVER AND PULL OUT THE ROTATING ASSEMBLY.**

**SUCTION TROUBLES**

- Pump not primed.
- Pump or suction pipe not completely filled with liquid.
- Suction lift too high.
- Insufficient margin between suction pressure and vapor pressure (available NPSH too low).
- Excessive amount of air or gas in liquid.
- Air pocket in suction line,
- Air leakage into suction line.
- Air leakage into pump through stuffing boxes.
- Foot valve too small.
- Foot valve partially clogged.
- Inlet of suction pipe insufficiently submerged,
- Water seal pipe plugged.
- Seal cage improperly located in stuffing box, preventing sealing fluid entering space to form the seal.

**SYSTEM TROUBLES**

- Speed too low.
- Speed too high.
- Wrong direction of rotation.
- Total head of system higher than pump design head.
- Total head of system lower than pump design head.
- Specific gravity of liquid different than design.
- Viscosity of liquid differs from that for which designed.
- Operation at very low capacity.
- Parallel operation of pumps unsuitable for such operation.

**MECHANICAL TROUBLES**

- Foreign matter in impeller.
- Misalignment.
- Foundation not rigid.
- Shaft bent.
- Rotating part rubbing on stationary part.
- Bearing worn.
- Wearing rings worn.
- Impeller damaged.
- Casing gasket defective, permitting internal leakage.
- Shaft or shaft sleeves worn or scored at the packing.
- Packing improperly installed.

- Incorrect type of packing for operation conditions.
- Shaft running off-center due to worn bearings or misalignment.
- Rotor out of balance resulting in vibration.
- Gland too tight, resulting in no Flow of liquid to packing.
- Failure to provide cooling liquid to water-cooled stuffing boxes.
- Excessive clearance at bottom of stuffing box between shaft and casing, causing packing to be forced into pump interior.
- Dirt or grit in sealing liquid, leading to scoring of shaft or shaft sleeve.
- Excessive thrust caused by a mechanical Failure inside the pump or by the failure of the hydraulic balancing device, if any.
- Excessive amount of grease or oil in the housing of on antifriction bearing or lack of cooling, causing excessive bearing temperature.
- Lack of lubrications.
- Improper installation of antifriction bearings (damage during assembly).
- Dirt getting into bearings.
- Rusting of bearings due to water getting into housing.
- Excessive cooling of water-cooled bearing resulting in condensation in the bearing housing of moisture from the atmosphere.



SERIES 840SC

# Exploded View

VERTICAL IN-LINE SPLIT COUPLING PUMP

## PARTS LIST

ITEM	DESCRIPTION	QTY
1	CASING	1
2	IMPELLER WEARING	1
3	MOTOR SHAFT KEY	1
4	WEAR RINGS	1
5	IMPELLER	1
6	BRACKET	1
7	MOTOR SHAFT KEY	1
8	CASING GASKET	1
9	IMPELLER WASHER	1
10	IMPELLER BOLT	1
11	PIPE PLUG 1/4" NPT	6
12	MECHANICAL SEAL	1

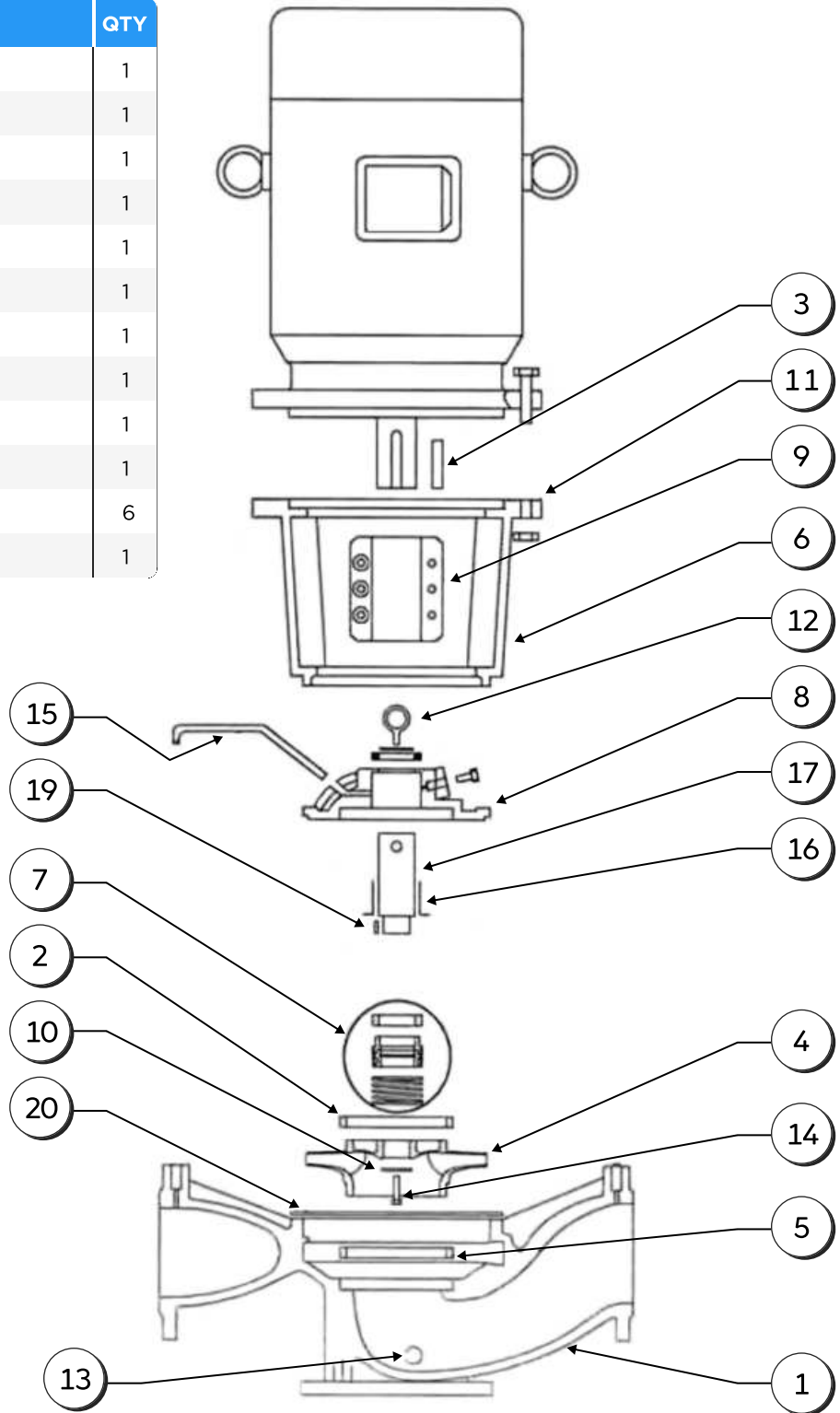

**SPARE PARTS CODE FOR SERIES 840SC PUMP**

MODEL & SIZE	CODE
4X4-8	125V200
4X4-10	125V250
4X4-12	125V315
6X6-8.5	150V200
6X6-10.2	150V250
6X6-12.79	150V315
6X6-15.5	150V400
8X8-8.5	200V200
8X8-10.2	200V250
8X8-12.79	200V315
8X8-15.94	200V400
10X10-13.7	250V315
10X10-17	250V400
12X12-16.5	300V235
12X12-17.4	300V300
12X12-11	300V315
12X12-22.8	300V380
12X12-17	300V400
14X14-13	350V300
14X14-16	350V400

RECOMMENDED SPARES PARTS SERIES 840SC MODEL 4X4X8 125V200

NO	PART NAME	PART NUMBER	STANDARD MATERIAL	PART NUMBER	OPTIONAL MATERIAL
1	Volute Casing	125V200-01	Cast Iron ASTMA48CL 30		Bronze STMB584C87400
1.1	Volute Casing				Stainless Steel 304
1.2	Volute Casing				Ductile Iron 300 PSI GGG50
1.3	Volute Casing				Cast Steel ASTMA216WCB
*2.1	Impeller Wearing	125V200-02-1	Cast Iron ASTMA48CL 30		
*2.2	Impeller Wearing			125V200-02-2	Brass
*2.3	Impeller Wearing			125V200-02-3	Bronze ASTMB584C87400
*2.4	Impeller Wearing			125V200-02-4	Stainless Steel 304
3	Motor Shaft Key	125V200-03	Steel		
*4	Impeller	125V200-04-1	Cast Iron ASTMA48CL 30	125V200-04-2	Brass
4	Impeller			125V200-04-3	Bronze ASTMB584C87400
4	Impeller			125V200-04-4	Stainless Steel 304
*5	Casing Wearing	125V200-05-1	Cast Iron ASTMA48CL 30	125V200-05-2	Brass
5	Casing Wearing			125V200-05-3	Bronze ASTMB584C87400
5	Casing Wearing			125V200-05-4	Stainless Steel 18-8 Open Designation
6	Bracket	125V200-06	Cast Iron ASTMA48CL 30 (advise motor frame)		
*7	Mechanical Seal	125V200-07	Buna/Silicone Carbide w/ Stainless Steel		Client's Choice
8	Mechanical Seal Cover	125V200-08	Cast Iron ASTMA48CL 30		
*9	Split Coupling	125V200-09	Cast Iron ASTMA48CL 30 (advise motor frame)		
10	Washer	125V200-10	Stainless Steel		
11	Motor Connection Flange	125V200-11	Cast Iron ASTMA48CL 30		
12	Holding Bolt and Washer	125V200-12	Steel		
13	Drain Plug	125V200-13	Steel		
14	Impeller Bolt	125V200-14	Stainless Steel		
15	Flush Line	125V200-15	Stainless Steel		
*16	Bearing Bushing	125V200-16	Bronze ASTMB584C87400		
*17	Pump Shaft	125V200-17	Stainless Steel		
19	Pump Shaft Key	125V200-19	Steel		
*20	Casing Gasket	125V200-20	Fiber Gasket Vellumoid		

RECOMMENDED SPARES PARTS SERIES 840SC MODEL 4X4X10 125V250

NO	PART NAME	PART NUMBER	STANDARD MATERIAL	PART NUMBER	OPTIONAL MATERIAL
1	Volute Casing	125V250-01	Cast Iron ASTMA48CL 30		Bronze STMB584C87400
1.1	Volute Casing				Stainless Steel 304
1.2	Volute Casing				Ductile Iron 300 PSI GGG50
1.3	Volute Casing				Cast Steel ASTMA216WCB
*2.1	Impeller Wearing	125V250-02-1	Cast Iron ASTMA48CL 30		
*2.2	Impeller Wearing			125V250-02-2	Brass
*2.3	Impeller Wearing			125V250-02-3	Bronze ASTMB584C87400
*2.4	Impeller Wearing			125V250-02-4	Stainless Steel 304
3	Motor Shaft Key	125V250-03	Steel		
*4	Impeller	125V250-04-1	Cast Iron ASTMA48CL 30	125V250-04-2	Brass
4	Impeller			125V250-04-3	Bronze ASTMB584C87400
4	Impeller			125V250-04-4	Stainless Steel 304
*5	Casing Wearing	125V250-05-1	Cast Iron ASTMA48CL 30	125V250-05-2	Brass
5	Casing Wearing			125V250-05-3	Bronze ASTMB584C87400
5	Casing Wearing			125V250-05-4	Stainless Steel 18-8 Open Designation
6	Bracket	125V250-06	Cast Iron ASTMA48CL 30 (advise motor frame)		
*7	Mechanical Seal	125V250-07	Buna/Silicone Carbide w/ Stainless Steel		Client's Choice
8	Mechanical Seal Cover	125V250-08	Cast Iron ASTMA48CL 30		
*9	Split Coupling	125V250-09	Cast Iron ASTMA48CL 30 (advise motor frame)		
10	Washer	125V250-10	Stainless Steel		
11	Motor Connection Flange	125V250-11	Cast Iron ASTMA48CL 30		
12	Holding Bolt and Washer	125V250-12	Steel		
13	Drain Plug	125V250-13	Steel		
14	Impeller Bolt	125V250-14	Stainless Steel		
15	Flush Line	125V250-15	Stainless Steel		
*16	Bearing Bushing	125V250-16	Bronze ASTMB584C87400		
*17	Pump Shaft	125V250-17	Stainless Steel		
19	Pump Shaft Key	125V250-19	Steel		
*20	Casing Gasket	125V250-20	Fiber Gasket Vellumoid		

RECOMMENDED SPARES PARTS SERIES 840SC MODEL 4X4X12 125V315

NO	PART NAME	PART NUMBER	STANDARD MATERIAL	PART NUMBER	OPTIONAL MATERIAL
1	Volute Casing	125V315-01	Cast Iron ASTMA48CL 30		Bronze STMB584C87400
1.1	Volute Casing				Stainless Steel 304
1.2	Volute Casing				Ductile Iron 300 PSI GGG50
1.3	Volute Casing				Cast Steel ASTMA216WCB
*2.1	Impeller Wearing	125V315-02-1	Cast Iron ASTMA48CL 30		
*2.2	Impeller Wearing			125V315-02-2	Brass
*2.3	Impeller Wearing			125V315-02-3	Bronze ASTMB584C87400
*2.4	Impeller Wearing			125V315-02-4	Stainless Steel 304
3	Motor Shaft Key	125V315-03	Steel		
*4	Impeller	125V315-04-1	Cast Iron ASTMA48CL 30	125V315-04-2	Brass
4	Impeller			125V315-04-3	Bronze ASTMB584C87400
4	Impeller			125V315-04-4	Stainless Steel 304
*5	Casing Wearing	125V315-05-1	Cast Iron ASTMA48CL 30	125V315-05-2	Brass
5	Casing Wearing			125V315-05-3	Bronze ASTMB584C87400
5	Casing Wearing			125V315-05-4	Stainless Steel 18-8 Open Designation
6	Bracket	125V315-06	Cast Iron ASTMA48CL 30 (advise motor frame)		
*7	Mechanical Seal	125V315-07	Buna/Silicone Carbide w/ Stainless Steel		Client's Choice
8	Mechanical Seal Cover	125V315-08	Cast Iron ASTMA48CL 30		
*9	Split Coupling	125V315-09	Cast Iron ASTMA48CL 30 (advise motor frame)		
10	Washer	125V315-10	Stainless Steel		
11	Motor Connection Flange	125V315-11	Cast Iron ASTMA48CL 30		
12	Holding Bolt and Washer	125V315-12	Steel		
13	Drain Plug	125V315-13	Steel		
14	Impeller Bolt	125V315-14	Stainless Steel		
15	Flush Line	125V315-15	Stainless Steel		
*16	Bearing Bushing	125V315-16	Bronze ASTMB584C87400		
*17	Pump Shaft	125V315-17	Stainless Steel		
19	Pump Shaft Key	125V315-19	Steel		
20	Casing Gasket	125V315-20	Fiber Gasket Vellumoid		

RECOMMENDED SPARES PARTS SERIES 840SC MODEL 6X6X8,5 150V200

NO	PART NAME	PART NUMBER	STANDARD MATERIAL	PART NUMBER	OPTIONAL MATERIAL
1	Volute Casing	150V200-01	Cast Iron ASTMA48CL 30		Bronze STMB584C87400
1.1	Volute Casing				Stainless Steel 304
1.2	Volute Casing				Ductile Iron 300 PSI GGG50
1.3	Volute Casing				Cast Steel ASTMA216WCB
*2.1	Impeller Wearing	150V200-02-1	Cast Iron ASTMA48CL 30		
*2.2	Impeller Wearing			150V200-02-2	Brass
*2.3	Impeller Wearing			150V200-02-3	Bronze ASTMB584C87400
*2.4	Impeller Wearing			150V200-02-4	Stainless Steel 304
3	Motor Shaft Key	150V200-03	Steel		
*4	Impeller	150V200-04-1	Cast Iron ASTMA48CL 30	150V200-04-2	Brass
4	Impeller			150V200-04-3	Bronze ASTMB584C87400
4	Impeller			150V200-04-4	Stainless Steel 304
*5	Casing Wearing	150V200-05-1	Cast Iron ASTMA48CL 30	150V200-05-2	Brass
5	Casing Wearing			150V200-05-3	Bronze ASTMB584C87400
5	Casing Wearing			150V200-05-4	Stainless Steel 18-8 Open Designation
6	Bracket	150V200-06	Cast Iron ASTMA48CL 30 (advise motor frame)		
*7	Mechanical Seal	150V200-07	Buna/Silicone Carbide w/ Stainless Steel		Client's Choice
8	Mechanical Seal Cover	150V200-08	Cast Iron ASTMA48CL 30		
*9	Split Coupling	150V200-09	Cast Iron ASTMA48CL 30 (advise motor frame)		
10	Washer	150V200-10	Stainless Steel		
11	Motor Connection Flange	150V200-11	Cast Iron ASTMA48CL 30		
12	Holding Bolt and Washer	150V200-12	Steel		
13	Drain Plug	150V200-13	Steel		
14	Impeller Bolt	150V200-14	Stainless Steel		
15	Flush Line	150V200-15	Stainless Steel		
*16	Bearing Bushing	150V200-16	Bronze ASTMB584C87400		
*17	Pump Shaft	150V200-17	Stainless Steel		
19	Pump Shaft Key	150V200-19	Steel		
20	Casing Gasket	150V200-20	Fiber Gasket Vellumoid		



RECOMMENDED SPARES PARTS SERIES 840SC MODEL 6X6X12 150V315

NO	PART NAME	PART NUMBER	STANDARD MATERIAL	PART NUMBER	OPTIONAL MATERIAL
1	Volute Casing	150V315-01	Cast Iron ASTMA48CL 30		Bronze STMB584C87400
1.1	Volute Casing				Stainless Steel 304
1.2	Volute Casing				Ductile Iron 300 PSI GGG50
1.3	Volute Casing				Cast Steel ASTMA216WCB
*2.1	Impeller Wearing	150V315-02-1	Cast Iron ASTMA48CL 30		
*2.2	Impeller Wearing			150V315-02-2	Brass
*2.3	Impeller Wearing			150V315-02-3	Bronze ASTMB584C87400
*2.4	Impeller Wearing			150V315-02-4	Stainless Steel 304
3	Motor Shaft Key	150V315-03	Steel		
*4	Impeller	150V315-04-1	Cast Iron ASTMA48CL 30	150V315-04-2	Brass
4	Impeller			150V315-04-3	Bronze ASTMB584C87400
4	Impeller			150V315-04-4	Stainless Steel 304
*5	Casing Wearing	150V315-05-1	Cast Iron ASTMA48CL 30	150V315-05-2	Brass
5	Casing Wearing			150V315-05-3	Bronze ASTMB584C87400
5	Casing Wearing			150V315-05-4	Stainless Steel 18-8 Open Designation
6	Bracket	150V315-06	Cast Iron ASTMA48CL 30 (advise motor frame)		
*7	Mechanical Seal	150V315-07	Buna/Silicone Carbide w/ Stainless Steel		Client's Choice
8	Mechanical Seal Cover	150V315-08	Cast Iron ASTMA48CL 30		
*9	Split Coupling	150V315-09	Cast Iron ASTMA48CL 30 (advise motor frame)		
10	Washer	150V315-10	Stainless Steel		
11	Motor Connection Flange	150V315-11	Cast Iron ASTMA48CL 30		
12	Holding Bolt and Washer	150V315-12	Steel		
13	Drain Plug	150V315-13	Steel		
14	Impeller Bolt	150V315-14	Stainless Steel		
15	Flush Line	150V315-15	Stainless Steel		
*16	Bearing Bushing	150V315-16	Bronze ASTMB584C87400		
*17	Pump Shaft	150V315-17	Stainless Steel		
19	Pump Shaft Key	150V315-19	Steel		
20	Casing Gasket	150V315-20	Fiber Gasket Vellumoid		

RECOMMENDED SPARES PARTS SERIES 840SC MODEL 6X6X15.5 150V400

NO	PART NAME	PART NUMBER	STANDARD MATERIAL	PART NUMBER	OPTIONAL MATERIAL
1	Volute Casing	150V400-01	Cast Iron ASTMA48CL 30		Bronze STMB584C87400
1.1	Volute Casing				Stainless Steel 304
1.2	Volute Casing				Ductile Iron 300 PSI GGG50
1.3	Volute Casing				Cast Steel ASTMA216WCB
*2.1	Impeller Wearing	150V400-02-1	Cast Iron ASTMA48CL 30		
*2.2	Impeller Wearing			150V400-02-2	Brass
*2.3	Impeller Wearing			150V400-02-3	Bronze ASTMB584C87400
*2.4	Impeller Wearing			150V 400-02-4	Stainless Steel 304
3	Motor Shaft Key	150V400-03	Steel		
*4	Impeller	150V400-04-1	Cast Iron ASTMA48CL 30	150V400-04-2	Brass
4	Impeller			150V400-04-3	Bronze ASTMB584C87400
4	Impeller			150V400-04-4	Stainless Steel 304
*5	Casing Wearing	150V400-05-1	Cast Iron ASTMA48CL 30	150V400-05-2	Brass
5	Casing Wearing			150V400-05-3	Bronze ASTMB584C87400
5	Casing Wearing			150V400-05-4	Stainless Steel 18-8 Open Designation
6	Bracket	150V400-06	Cast Iron ASTMA48CL 30 (advise motor frame)		
*7	Mechanical Seal	150V400-07	Buna/Silicone Carbide w/ Stainless Steel		Client's Choice
8	Mechanical Seal Cover	150V400-08	Cast Iron ASTMA48CL 30		
*9	Split Coupling	150V400-09	Cast Iron ASTMA48CL 30 (advise motor frame)		
10	Washer	150V400-10	Stainless Steel		
11	Motor Connection Flange	1501/400-11	Cast Iron ASTMA48CL 30		
12	Holding Bolt and Washer	1501/400-12	Steel		
13	Drain Plug	1501/400-13	Steel		
14	Impeller Bolt	150V400-14	Stainless Steel		
15	Flush Line	150V400-15	Stainless Steel		
*16	Bearing Bushing	150V400-16	Bronze ASTMB584C87400		
*17	Pump Shaft	150V400-17	Stainless Steel		
19	Pump Shaft Key	150V400-19	Steel		
20	Casing Gasket	150V400-20	Fiber Gasket Vellumoid		

**RECOMMENDED SPARES PARTS SERIES 840SC MODEL 8X8X8.5 200V200**

NO	PART NAME	PART NUMBER	STANDARD MATERIAL	PART NUMBER	OPTIONAL MATERIAL
1	Volute Casing	200V200-01	Cast Iron ASTMA48CL 30		Bronze STMB584C87400
1.1	Volute Casing				Stainless Steel 304
1.2	Volute Casing				Ductile Iron 300 PSI GGG50
1.3	Volute Casing				Cast Steel ASTMA216WCB
*2.1	Impeller Wearing	200V200-02-1	Cast Iron ASTMA48CL 30		
*2.2	Impeller Wearing			200V200-02-2	Brass
*2.3	Impeller Wearing			200V200-02-3	Bronze ASTMB584C87400
*2.4	Impeller Wearing			200V200-02-4	Stainless Steel 304
3	Motor Shaft Key	200V200-03	Steel		
*4	Impeller	200V200-04-1	Cast Iron ASTMA48CL 30	200V200-04-2	Brass
4	Impeller			200V200-04-3	Bronze ASTMB584C87400
4	Impeller			200V200-04-4	Stainless Steel 304
*5	Casing Wearing	200V200-05-1	Cast Iron ASTMA48CL 30	200V200-05-2	Brass
5	Casing Wearing			200V200-05-3	Bronze ASTMB584C87400
5	Casing Wearing			200V200-05-4	Stainless Steel 18-8 Open Designation
6	Bracket	200V200-06	Cast Iron ASTMA48CL 30 (advise motor frame)		
*7	Mechanical Seal	200V200-07	Buna/Silicone Carbide w/ Stainless Steel		Client's Choice
8	Mechanical Seal Cover	200V200-08	Cast Iron ASTMA48CL 30		
*9	Split Coupling	200V200-09	Cast Iron ASTMA48CL 30 (advise motor frame)		
10	Washer	200V200-10	Stainless Steel		
11	Motor Connection Flange	200V200-11	Cast Iron ASTMA48CL 30		
12	Holding Bolt and Washer	200V200-12	Steel		
13	Drain Plug	200V200-13	Steel		
14	Impeller Bolt	200V200-14	Stainless Steel		
15	Flush Line	200V200-15	Stainless Steel		
*16	Bearing Bushing	200V200-16	Bronze ASTMB584C87400		
*17	Pump Shaft	200V200-17	Stainless Steel		
19	Pump Shaft Key	200V200-19	Steel		
20	Casing Gasket	200V200-20	Fiber Gasket Vellumoid		

**RECOMMENDED SPARES PARTS SERIES 840SC MODEL 6X6X10.2 150V250**

NO	PART NAME	PART NUMBER	STANDARD MATERIAL	PART NUMBER	OPTIONAL MATERIAL
1	Volute Casing	150V250-01	Cast Iron ASTMA48CL 30		Bronze STMB584C87400
1.1	Volute Casing				Stainless Steel 304
1.2	Volute Casing				Ductile Iron 300 PSI GGG50
1.3	Volute Casing				Cast Steel ASTMA216WCB
*2.1	Impeller Wearing	150V250-02-1	Cast Iron ASTMA48CL 30		
*2.2	Impeller Wearing			150V250-02-2	Brass
*2.3	Impeller Wearing			150V250-02-3	Bronze ASTMB584C87400
*2.4	Impeller Wearing			150V250-02-4	Stainless Steel 304
3	Motor Shaft Key	150V250-03	Steel		
*4	Impeller	150V250-04-1	Cast Iron ASTMA48CL 30	150V250-04-2	Brass
4	Impeller			150V250-04-3	Bronze ASTMB584C87400
4	Impeller			150V250-04-4	Stainless Steel 304
*5	Casing Wearing	150V250-05-1	Cast Iron ASTMA48CL 30	150V250-05-2	Brass
5	Casing Wearing			150V250-05-3	Bronze ASTMB584C87400
5	Casing Wearing			150V250-05-4	Stainless Steel 18-8 Open Designation
6	Bracket	150V250-06	Cast Iron ASTMA48CL 30 (advise motor frame)		
*7	Mechanical Seal	150V250-07	Buna/Silicone Carbide w/ Stainless Steel		Client's Choice
8	Mechanical Seal Cover	150V250-08	Cast Iron ASTMA48CL 30		
*9	Split Coupling	150V250-09	Cast Iron ASTMA48CL 30 (advise motor frame)		
10	Washer	150V250-10	Stainless Steel		
11	Motor Connection Flange	150V250-11	Cast Iron ASTMA48CL 30		
12	Holding Bolt and Washer	150V250-12	Steel		
13	Drain Plug	150V250-13	Steel		
14	Impeller Bolt	150V250-14	Stainless Steel		
15	Flush Line	150V250-15	Stainless Steel		
*16	Bearing Bushing	150V250-16	Bronze ASTMB584C87400		
*17	Pump Shaft	150V250-17	Stainless Steel		
19	Pump Shaft Key	150V250-19	Steel		
20	Casing Gasket	150V250-20	Fiber Gasket Vellumoid		

**RECOMMENDED SPARES PARTS SERIES 840SC MODEL 8X8X10.2 200V250**

NO	PART NAME	PART NUMBER	STANDARD MATERIAL	PART NUMBER	OPTIONAL MATERIAL
1	Volute Casing	200V250-01	Cast Iron ASTMA48CL 30		Bronze STMB584C87400
1.1	Volute Casing				Stainless Steel 304
1.2	Volute Casing				Ductile Iron 300 PSI GGG50
1.3	Volute Casing				Cast Steel ASTMA216WCB
*2.1	Impeller Wearing	200V250-02-1	Cast Iron ASTMA48CL 30		
*2.2	Impeller Wearing			200V250-02-2	Brass
*2.3	Impeller Wearing			200V250-02-3	Bronze ASTMB584C87400
*2.4	Impeller Wearing			200V250-02-4	Stainless Steel 304
3	Motor Shaft Key	200V250-03	Steel		
*4	Impeller	200V250-04-1	Cast Iron ASTMA48CL 30	200V250-04-2	Brass
4	Impeller			200V250-04-3	Bronze ASTMB584C87400
4	Impeller			200V250-04-4	Stainless Steel 304
*5	Casing Wearing	200V250-05-1	Cast Iron ASTMA48CL 30	200V250-05-2	Brass
5	Casing Wearing			200V250-05-3	Bronze ASTMB584C87400
5	Casing Wearing			200V250-05-4	Stainless Steel 18-8 Open Designation
6	Bracket	200V250-06	Cast Iron ASTMA48CL 30 (advise motor frame)		
*7	Mechanical Seal	200V250-07	Buna/Silicone Carbide w/ Stainless Steel		Client's Choice
8	Mechanical Seal Cover	200V250-08	Cast Iron ASTMA48CL 30		
*9	Split Coupling	200V250-09	Cast Iron ASTMA48CL 30 (advise motor frame)		
10	Washer	200V250-10	Stainless Steel		
11	Motor Connection Flange	200V250-11	Cast Iron ASTMA48CL 30		
12	Holding Bolt and Washer	200V250-12	Steel		
13	Drain Plug	200V250-13	Steel		
14	Impeller Bolt	200V250-14	Stainless Steel		
15	Flush Line	200V250-15	Stainless Steel		
*16	Bearing Bushing	200V250-16	Bronze ASTMB584C87400		
*17	Pump Shaft	200V250-17	Stainless Steel		
19	Pump Shaft Key	200V250-19	Steel		
20	Casing Gasket	200V250-20	Fiber Gasket Vellumoid		

RECOMMENDED SPARES PARTS SERIES 840SC MODEL 8X8X12 200V315

NO	PART NAME	PART NUMBER	STANDARD MATERIAL	PART NUMBER	OPTIONAL MATERIAL
1	Volute Casing	200V315-01	Cast Iron ASTMA48CL 30		Bronze STMB584C87400
1.1	Volute Casing				Stainless Steel 304
1.2	Volute Casing				Ductile Iron 300 PSI GGG50
1.3	Volute Casing				Cast Steel ASTMA216WCB
*2.1	Impeller Wearing	200V315-02-1	Cast Iron ASTMA48CL 30		
*2.2	Impeller Wearing			200V315-02-2	Brass
*2.3	Impeller Wearing			200V315-02-3	Bronze ASTMB584C87400
*2.4	Impeller Wearing			200V315-02-4	Stainless Steel 304
3	Motor Shaft Key	200V315-03	Steel		
*4	Impeller	200V315-04-1	Cast Iron ASTMA48CL 30	200V315-04-2	Brass
4	Impeller			200V315-04-3	Bronze ASTMB584C87400
4	Impeller			200V315-04-4	Stainless Steel 304
*5	Casing Wearing	200V315-05-1	Cast Iron ASTMA48CL 30	200V315-05-2	Brass
5	Casing Wearing			200V315-05-3	Bronze ASTMB584C87400
5	Casing Wearing			200V315-05-4	Stainless Steel 18-8 Open Designation
6	Bracket	200V315-06	Cast Iron ASTMA48CL 30 (advise motor frame)		
*7	Mechanical Seal	200V315-07	Buna/Silicone Carbide w/ Stainless Steel		Client's Choice
8	Mechanical Seal Cover	200V315-08	Cast Iron ASTMA48CL 30		
*9	Split Coupling	200V315-09	Cast Iron ASTMA48CL 30 (advise motor frame)		
10	Washer	200V315-10	Stainless Steel		
11	Motor Connection Flange	200V315-11	Cast Iron ASTMA48CL 30		
12	Holding Bolt and Washer	200V315-12	Steel		
13	Drain Plug	200V315-13	Steel		
14	Impeller Bolt	200V315-14	Stainless Steel		
15	Flush Line	200V315-15	Stainless Steel		
*16	Bearing Bushing	200V315-16	Bronze ASTMB584C87400		
*17	Pump Shaft	200V315-17	Stainless Steel		
19	Pump Shaft Key	200V315-19	Steel		
20	Casing Gasket	200V315-20	Fiber Gasket Vellumoid		



RECOMMENDED SPARES PARTS SERIES 840SC MODEL 8X8X15 200V400

NO	PART NAME	PART NUMBER	STANDARD MATERIAL	PART NUMBER	OPTIONAL MATERIAL
1	Volute Casing	200V400-01	Cast Iron ASTMA48CL 30		Bronze STMB584C87400
1.1	Volute Casing				Stainless Steel 304
1.2	Volute Casing				Ductile Iron 300 PSI GGG50
1.3	Volute Casing				Cast Steel ASTMA216WCB
*2.1	Impeller Wearing	200V400-02-1	Cast Iron ASTMA48CL 30		
*2.2	Impeller Wearing			200V400-02-2	Brass
*2.3	Impeller Wearing			200V400-02-3	Bronze ASTMB584C87400
*2.4	Impeller Wearing			200V400-02-4	Stainless Steel 304
3	Motor Shaft Key	200V400-03	Steel		
*4	Impeller	200V400-04-1	Cast Iron ASTMA48CL 30	200V400-04-2	Brass
4	Impeller			200V400-04-3	Bronze ASTMB584C87400
4	Impeller			200V400-04-4	Stainless Steel 304
*5	Casing Wearing	200V400-05-1	Cast Iron ASTMA48CL 30	200V400-05-2	Brass
5	Casing Wearing			200V400-05-3	Bronze ASTMB584C87400
5	Casing Wearing			200V400-05-4	Stainless Steel 18-8 Open Designation
6	Bracket	200V400-06	Cast Iron ASTMA48CL 30 (advise motor frame)		
*7	Mechanical Seal	200V400-07	Buna/Silicone Carbide w/ Stainless Steel		Client's Choice
8	Mechanical Seal Cover	200V400-08	Cast Iron ASTMA48CL 30		
*9	Split Coupling	200V400-09	Cast Iron ASTMA48CL 30 (advise motor frame)		
10	Washer	200V400-10	Stainless Steel		
11	Motor Connection Flange	200V400-11	Cast Iron ASTMA48CL 30		
12	Holding Bolt and Washer	200V400-12	Steel		
13	Drain Plug	200V400-13	Steel		
14	Impeller Bolt	200V400-14	Stainless Steel		
15	Flush Line	200V400-15	Stainless Steel		
*16	Bearing Bushing	200V400-16	Bronze ASTMB584C87400		
*17	Pump Shaft	200V400-17	Stainless Steel		
19	Pump Shaft Key	200V400-19	Steel		
20	Casing Gasket	200V400-20	Fiber Gasket Vellumoid		

RECOMMENDED SPARES PARTS SERIES 840SC MODEL 10X10X13.7 250V315

NO	PART NAME	PART NUMBER	STANDARD MATERIAL	PART NUMBER	OPTIONAL MATERIAL
1	Volute Casing	250V315-01	Cast Iron ASTMA48CL 30		Bronze STMB584C87400
1.1	Volute Casing				Stainless Steel 304
1.2	Volute Casing				Ductile Iron 300 PSI GGG50
1.3	Volute Casing				Cast Steel ASTMA216WCB
*2.1	Impeller Wearing	250V315-02-1	Cast Iron ASTMA48CL 30		
*2.2	Impeller Wearing			250V315-02-2	Brass
*2.3	Impeller Wearing			250V315-02-3	Bronze ASTMB584C87400
*2.4	Impeller Wearing			250V315-02-4	Stainless Steel 304
3	Motor Shaft Key	250V315-03	Steel		
*4	Impeller	250V315-04-1	Cast Iron ASTMA48CL 30	250V315-04-2	Brass
4	Impeller			250V315-04-3	Bronze ASTMB584C87400
4	Impeller			250V315-04-4	Stainless Steel 304
*5	Casing Wearing	250V315-05-1	Cast Iron ASTMA48CL 30	250V315-05-2	Brass
5	Casing Wearing			250V315-05-3	Bronze ASTMB584C87400
5	Casing Wearing			250V315-05-4	Stainless Steel 18-8 Open Designation
6	Bracket	250V315-06	Cast Iron ASTMA48CL 30 (advise motor frame)		
*7	Mechanical Seal	250V315-07	Buna/Silicone Carbide w/ Stainless Steel		Client's Choice
8	Mechanical Seal Cover	250V315-08	Cast Iron ASTMA48CL 30		
*9	Split Coupling	250V315-09	Cast Iron ASTMA48CL 30 (advise motor frame)		
10	Washer	250V315-10	Stainless Steel		
11	Motor Connection Flange	250V315-11	Cast Iron ASTMA48CL 30		
12	Holding Bolt and Washer	250V315-12	Steel		
13	Drain Plug	250V315-13	Steel		
14	Impeller Bolt	250V315-14	Stainless Steel		
15	Flush Line	250V315-15	Stainless Steel		
*16	Bearing Bushing	250V315-16	Bronze ASTMB584C87400		
*17	Pump Shaft	250V315-17	Stainless Steel		
19	Pump Shaft Key	250V315-19	Steel		
20	Casing Gasket	250V315-20	Fiber Gasket Vellumoid		

**RECOMMENDED SPARES PARTS SERIES 840SC MODEL 10X10X17 250V400**

NO	PART NAME	PART NUMBER	STANDARD MATERIAL	PART NUMBER	OPTIONAL MATERIAL
1	Volute Casing	250V400-01	Cast Iron ASTMA48CL 30		Bronze STMB584C87400
1.1	Volute Casing				Stainless Steel 304
1.2	Volute Casing				Ductile Iron 300 PSI GGG50
1.3	Volute Casing				Cast Steel ASTMA216WCB
*2.1	Impeller Wearing	250V400-02-1	Cast Iron ASTMA48CL 30		
*2.2	Impeller Wearing			250V400-02-2	Brass
*2.3	Impeller Wearing			250V400-02-3	Bronze ASTMB584C87400
*2.4	Impeller Wearing			250V400-02-4	Stainless Steel 304
3	Motor Shaft Key	250V400-03	Steel		
*4	Impeller	250V400-04-1	Cast Iron ASTMA48CL 30	250V400-04-2	Brass
4	Impeller			250V400-04-3	Bronze ASTMB584C87400
4	Impeller			250V400-04-4	Stainless Steel 304
*5	Casing Wearing	250V400-05-1	Cast Iron ASTMA48CL 30	250V400-05-2	Brass
5	Casing Wearing			250V400-05-3	Bronze ASTMB584C87400
5	Casing Wearing			250V400-05-4	Stainless Steel 18-8 Open Designation
6	Bracket	250V400-06	Cast Iron ASTMA48CL 30 (advise motor frame)		
*7	Mechanical Seal	250V400-07	Buna/Silicone Carbide w/ Stainless Steel		Client's Choice
8	Mechanical Seal Cover	250V400-08	Cast Iron ASTMA48CL 30		
*9	Split Coupling	250V400-09	Cast Iron ASTMA48CL 30 (advise motor frame)		
10	Washer	250V400-10	Stainless Steel		
11	Motor Connection Flange	250V400-11	Cast Iron ASTMA48CL 30		
12	Holding Bolt and Washer	250V400-12	Steel		
13	Drain Plug	250V400-13	Steel		
14	Impeller Bolt	250V400-14	Stainless Steel		
15	Flush Line	250V400-15	Stainless Steel		
*16	Bearing Bushing	250V400-16	Bronze ASTMB584C87400		
*17	Pump Shaft	250V400-17	Stainless Steel		
19	Pump Shaft Key	250V400-19	Steel		
20	Casing Gasket	250V400-20	Fiber Gasket Vellumoid		

RECOMMENDED SPARES PARTS SERIES 840SC MODEL 12X12X11 300V315

NO	PART NAME	PART NUMBER	STANDARD MATERIAL	PART NUMBER	OPTIONAL MATERIAL
1	Volute Casing	300V315-01	Cast Iron ASTMA48CL 30		Bronze STMB584C87400
1.1	Volute Casing				Stainless Steel 304
1.2	Volute Casing				Ductile Iron 300 PSI GGG50
1.3	Volute Casing				Cast Steel ASTMA216WCB
*2.1	Impeller Wearing	300V315-02-1	Cast Iron ASTMA48CL 30		
*2.2	Impeller Wearing			300V315-02-2	Brass
*2.3	Impeller Wearing			300V315-02-3	Bronze ASTMB584C87400
*2.4	Impeller Wearing			300V315-02-4	Stainless Steel 304
3	Motor Shaft Key	300V315-03	Steel		
*4	Impeller	300V315-04-1	Cast Iron ASTMA48CL 30	300V315-04-2	Brass
4	Impeller			300V315-04-3	Bronze ASTMB584C87400
4	Impeller			300V315-04-4	Stainless Steel 304
*5	Casing Wearing	300V315-05-1	Cast Iron ASTMA48CL 30	300V315-05-2	Brass
5	Casing Wearing			300V315-05-3	Bronze ASTMB584C87400
5	Casing Wearing			300V315-05-4	Stainless Steel 18-8 Open Designation
6	Bracket	300V315-06	Cast Iron ASTMA48CL 30 (advise motor frame)		
*7	Mechanical Seal	300V315-07	Buna/Silicone Carbide w/ Stainless Steel		Client's Choice
8	Mechanical Seal Cover	300V315-08	Cast Iron ASTMA48CL 30		
*9	Split Coupling	300V315-09	Cast Iron ASTMA48CL 30 (advise motor frame)		
10	Washer	300V315-10	Stainless Steel		
11	Motor Connection Flange	300V315-11	Cast Iron ASTMA48CL 30		
12	Holding Bolt and Washer	300V315-12	Steel		
13	Drain Plug	300V315-13	Steel		
14	Impeller Bolt	300V315-14	Stainless Steel		
15	Flush Line	300V315-15	Stainless Steel		
*16	Bearing Bushing	300V315-16	Bronze ASTMB584C87400		
*17	Pump Shaft	300V315-17	Stainless Steel		
19	Pump Shaft Key	300V315-19	Steel		
20	Casing Gasket	300V315-20	Fiber Gasket Vellumoid		

RECOMMENDED SPARES PARTS SERIES 840SC MODEL 12X12X16.5 300V235

NO	PART NAME	PART NUMBER	STANDARD MATERIAL	PART NUMBER	OPTIONAL MATERIAL
1	Volute Casing	300V235-01	Cast Iron ASTMA48CL 30		Bronze STMB584C87400
1.1	Volute Casing				Stainless Steel 304
1.2	Volute Casing				Ductile Iron 300 PSI GGG50
1.3	Volute Casing				Cast Steel ASTMA216WCB
*2.1	Impeller Wearing	300V235-02-1	Cast Iron ASTMA48CL 30		
*2.2	Impeller Wearing			300V235-02-2	Brass
*2.3	Impeller Wearing			300V235-02-3	Bronze ASTMB584C87400
*2.4	Impeller Wearing			300V235-02-4	Stainless Steel 304
3	Motor Shaft Key	300V235-03	Steel		
*4	Impeller	300V235-04-1	Cast Iron ASTMA48CL 30	300V235-04-2	Brass
4	Impeller			300V235-04-3	Bronze ASTMB584C87400
4	Impeller			300V235-04-4	Stainless Steel 304
*5	Casing Wearing	300V235-05-1	Cast Iron ASTMA48CL 30	300V235-05-2	Brass
5	Casing Wearing			300V235-05-3	Bronze ASTMB584C87400
5	Casing Wearing			300V235-05-4	Stainless Steel 18-8 Open Designation
6	Bracket	300V235-06	Cast Iron ASTMA48CL 30 (advise motor frame)		
*7	Mechanical Seal	300V235-07	Buna/Silicone Carbide w/ Stainless Steel		Client's Choice
8	Mechanical Seal Cover	300V235-08	Cast Iron ASTMA48CL 30		
*9	Split Coupling	300V235-09	Cast Iron ASTMA48CL 30 (advise motor frame)		
10	Washer	300V235-10	Stainless Steel		
11	Motor Connection Flange	300V235-11	Cast Iron ASTMA48CL 30		
12	Holding Bolt and Washer	300V235-12	Steel		
13	Drain Plug	300V235-13	Steel		
14	Impeller Bolt	300V235-14	Stainless Steel		
15	Flush Line	300V235-15	Stainless Steel		
*16	Bearing Bushing	300V235-16	Bronze ASTMB584C87400		
*17	Pump Shaft	300V235-17	Stainless Steel		
19	Pump Shaft Key	300V235-19	Steel		
20	Casing Gasket	300V235-20	Fiber Gasket Vellumoid		

RECOMMENDED SPARES PARTS SERIES 840SC MODEL 12X12X17 300V400

NO	PART NAME	PART NUMBER	STANDARD MATERIAL	PART NUMBER	OPTIONAL MATERIAL
1	Volute Casing	300V400-01	Cast Iron ASTMA48CL 30		Bronze STMB584C87400
1.1	Volute Casing				Stainless Steel 304
1.2	Volute Casing				Ductile Iron 300 PSI GGG50
1.3	Volute Casing				Cast Steel ASTMA216WCB
*2.1	Impeller Wearing	300V400-02-1	Cast Iron ASTMA48CL 30		
*2.2	Impeller Wearing			300V400-02-2	Brass
*2.3	Impeller Wearing			300V400-02-3	Bronze ASTMB584C87400
*2.4	Impeller Wearing			300V400-02-4	Stainless Steel 304
3	Motor Shaft Key	300V400-03	Steel		
*4	Impeller	300V400-04-1	Cast Iron ASTMA48CL 30	300V400-04-2	Brass
4	Impeller			300V400-04-3	Bronze ASTMB584C87400
4	Impeller			300V400-04-4	Stainless Steel 304
*5	Casing Wearing	300V400-05-1	Cast Iron ASTMA48CL 30	300V400-05-2	Brass
5	Casing Wearing			300V400-05-3	Bronze ASTMB584C87400
5	Casing Wearing			300V400-05-4	Stainless Steel 18-8 Open Designation
6	Bracket	300V400-06	Cast Iron ASTMA48CL 30 (advise motor frame)		
*7	Mechanical Seal	300V400-07	Buna/Silicone Carbide w/ Stainless Steel		Client's Choice
8	Mechanical Seal Cover	300V400-08	Cast Iron ASTMA48CL 30		
*9	Split Coupling	300V400-09	Cast Iron ASTMA48CL 30 (advise motor frame)		
10	Washer	300V400-10	Stainless Steel		
11	Motor Connection Flange	300V400-11	Cast Iron ASTMA48CL 30		
12	Holding Bolt and Washer	300V400-12	Steel		
13	Drain Plug	300V400-13	Steel		
14	Impeller Bolt	300V400-14	Stainless Steel		
15	Flush Line	300V400-15	Stainless Steel		
*16	Bearing Bushing	300V400-16	Bronze ASTMB584C87400		
*17	Pump Shaft	300V400-17	Stainless Steel		
19	Pump Shaft Key	300V400-19	Steel		
20	Casing Gasket	300V400-20	Fiber Gasket Vellumoid		



RECOMMENDED SPARES PARTS SERIES 840SC MODEL 12X12X17.4 300V300

NO	PART NAME	PART NUMBER	STANDARD MATERIAL	PART NUMBER	OPTIONAL MATERIAL
1	Volute Casing	300V300-01	Cast Iron ASTMA48CL 30		Bronze STMB584C87400
1.1	Volute Casing				Stainless Steel 304
1.2	Volute Casing				Ductile Iron 300 PSI GGG50
1.3	Volute Casing				Cast Steel ASTMA216WCB
*2.1	Impeller Wearing	300V300-02-1	Cast Iron ASTMA48CL 30		
*2.2	Impeller Wearing			300V300-02-2	Brass
*2.3	Impeller Wearing			300V300-02-3	Bronze ASTMB584C87400
*2.4	Impeller Wearing			300V300-02-4	Stainless Steel 304
3	Motor Shaft Key	300V300-03	Steel		
*4	Impeller	300V300-04-1	Cast Iron ASTMA48CL 30	300V300-04-2	Brass
4	Impeller			300V300-04-3	Bronze ASTMB584C87400
4	Impeller			300V300-04-4	Stainless Steel 304
*5	Casing Wearing	300V300-05-1	Cast Iron ASTMA48CL 30	300V300-05-2	Brass
5	Casing Wearing			300V300-05-3	Bronze ASTMB584C87400
5	Casing Wearing			300V300-05-4	Stainless Steel 18-8 Open Designation
6	Bracket	300V300-06	Cast Iron ASTMA48CL 30 (advise motor frame)		
*7	Mechanical Seal	300V300-07	Buna/Silicone Carbide w/ Stainless Steel		Client's Choice
8	Mechanical Seal Cover	300V300-08	Cast Iron ASTMA48CL 30		
*9	Split Coupling	300V300-09	Cast Iron ASTMA48CL 30 (advise motor frame)		
10	Washer	300V300-10	Stainless Steel		
11	Motor Connection Flange	300V300-11	Cast Iron ASTMA48CL 30		
12	Holding Bolt and Washer	300V300-12	Steel		
13	Drain Plug	300V300-13	Steel		
14	Impeller Bolt	300V300-14	Stainless Steel		
15	Flush Line	300V300-15	Stainless Steel		
*16	Bearing Bushing	300V300-16	Bronze ASTMB584C87400		
*17	Pump Shaft	300V300-17	Stainless Steel		
19	Pump Shaft Key	300V300-19	Steel		
20	Casing Gasket	300V300-20	Fiber Gasket Vellumoid		

**RECOMMENDED SPARES PARTS SERIES 840SC MODEL 12X12X22.8 300V380**

NO	PART NAME	PART NUMBER	STANDARD MATERIAL	PART NUMBER	OPTIONAL MATERIAL
1	Volute Casing	300V380-01	Cast Iron ASTMA48CL 30		Bronze STMB584C87400
1.1	Volute Casing				Stainless Steel 304
1.2	Volute Casing				Ductile Iron 300 PSI GGG50
1.3	Volute Casing				Cast Steel ASTMA216WCB
*2.1	Impeller Wearing	300V380-02-1	Cast Iron ASTMA48CL 30		
*2.2	Impeller Wearing			300V380-02-2	Brass
*2.3	Impeller Wearing			300V380-02-3	Bronze ASTMB584C87400
*2.4	Impeller Wearing			300V380-02-4	Stainless Steel 304
3	Motor Shaft Key	300V380-03	Steel		
*4	Impeller	300V380-04-1	Cast Iron ASTMA48CL 30	300V380-04-2	Brass
4	Impeller			300V380-04-3	Bronze ASTMB584C87400
4	Impeller			300V380-04-4	Stainless Steel 304
*5	Casing Wearing	300V380-05-1	Cast Iron ASTMA48CL 30	300V380-05-2	Brass
5	Casing Wearing			300V380-05-3	Bronze ASTMB584C87400
5	Casing Wearing			300V380-05-4	Stainless Steel 18-8 Open Designation
6	Bracket	300V380-06	Cast Iron ASTMA48CL 30 (advise motor frame)		
*7	Mechanical Seal	300V380-07	Buna/Silicone Carbide w/ Stainless Steel		Client's Choice
8	Mechanical Seal Cover	300V380-08	Cast Iron ASTMA48CL 30		
*9	Split Coupling	300V380-09	Cast Iron ASTMA48CL 30 (advise motor frame)		
10	Washer	300V380-10	Stainless Steel		
11	Motor Connection Flange	300V380-11	Cast Iron ASTMA48CL 30		
12	Holding Bolt and Washer	300V380-12	Steel		
13	Drain Plug	300V380-13	Steel		
14	Impeller Bolt	300V380-14	Stainless Steel		
15	Flush Line	300V380-15	Stainless Steel		
*16	Bearing Bushing	300V380-16	Bronze ASTMB584C87400		
*17	Pump Shaft	300V380-17	Stainless Steel		
19	Pump Shaft Key	300V380-19	Steel		
20	Casing Gasket	300V380-20	Fiber Gasket Vellumoid		

**RECOMMENDED SPARES PARTS SERIES 840SC MODEL 14X14X13 350V300**

NO	PART NAME	PART NUMBER	STANDARD MATERIAL	PART NUMBER	OPTIONAL MATERIAL
1	Volute Casing	350V300-01	Cast Iron ASTMA48CL 30		Bronze STMB584C87400
1.1	Volute Casing				Stainless Steel 304
1.2	Volute Casing				Ductile Iron 300 PSI GGG50
1.3	Volute Casing				Cast Steel ASTMA216WCB
*2.1	Impeller Wearing	350V300-02-1	Cast Iron ASTMA48CL 30		
*2.2	Impeller Wearing			350V300-02-2	Brass
*2.3	Impeller Wearing			350V300-02-3	Bronze ASTMB584C87400
*2.4	Impeller Wearing			350V300-02-4	Stainless Steel 304
3	Motor Shaft Key	350V300-03	Steel		
*4	Impeller	350V300-04-1	Cast Iron ASTMA48CL 30	350V300-04-2	Brass
4	Impeller			350V300-04-3	Bronze ASTMB584C87400
4	Impeller			350V300-04-4	Stainless Steel 304
*5	Casing Wearing	350V300-05-1	Cast Iron ASTMA48CL 30	350V300-05-2	Brass
5	Casing Wearing			350V300-05-3	Bronze ASTMB584C87400
5	Casing Wearing			350V300-05-4	Stainless Steel 18-8 Open Designation
6	Bracket	350V300-06	Cast Iron ASTMA48CL 30 (advise motor frame)		
*7	Mechanical Seal	350V300-07	Buna/Silicone Carbide w/ Stainless Steel		Client's Choice
8	Mechanical Seal Cover	350V300-08	Cast Iron ASTMA48CL 30		
*9	Split Coupling	350V300-09	Cast Iron ASTMA48CL 30 (advise motor frame)		
10	Washer	350V300-10	Stainless Steel		
11	Motor Connection Flange	350V300-11	Cast Iron ASTMA48CL 30		
12	Holding Bolt and Washer	350V300-12	Steel		
13	Drain Plug	350V300-13	Steel		
14	Impeller Bolt	350V300-14	Stainless Steel		
15	Flush Line	350V300-15	Stainless Steel		
*16	Bearing Bushing	350V300-16	Bronze ASTMB584C87400		
*17	Pump Shaft	350V300-17	Stainless Steel		
19	Pump Shaft Key	350V300-19	Steel		
20	Casing Gasket	350V300-20	Fiber Gasket Vellumoid		

RECOMMENDED SPARES PARTS SERIES 840SC MODEL 14X14X16 350V400

NO	PART NAME	PART NUMBER	STANDARD MATERIAL	PART NUMBER	OPTIONAL MATERIAL
1	Volute Casing	350V400-01	Cast Iron ASTMA48CL 30		Bronze STMB584C87400
1.1	Volute Casing				Stainless Steel 304
1.2	Volute Casing				Ductile Iron 300 PSI GGG50
1.3	Volute Casing				Cast Steel ASTMA216WCB
*2.1	Impeller Wearing	350V400-02-1	Cast Iron ASTMA48CL 30		
*2.2	Impeller Wearing			350V400-02-2	Brass
*2.3	Impeller Wearing			350V400-02-3	Bronze ASTMB584C87400
*2.4	Impeller Wearing			350V400-02-4	Stainless Steel 304
3	Motor Shaft Key	350V400-03	Steel		
*4	Impeller	350V400-04-1	Cast Iron ASTMA48CL 30	350V400-04-2	Brass
4	Impeller			350V400-04-3	Bronze ASTMB584C87400
4	Impeller			350V400-04-4	Stainless Steel 304
*5	Casing Wearing	350V400-05-1	Cast Iron ASTMA48CL 30	350V400-05-2	Brass
5	Casing Wearing			350V400-05-3	Bronze ASTMB584C87400
5	Casing Wearing			350V400-05-4	Stainless Steel 18-8 Open Designation
6	Bracket	350V400-06	Cast Iron ASTMA48CL 30 (advise motor frame)		
*7	Mechanical Seal	350V400-07	Buna/Silicone Carbide w/ Stainless Steel		Client's Choice
8	Mechanical Seal Cover	350V400-08	Cast Iron ASTMA48CL 30		
*9	Split Coupling	350V400-09	Cast Iron ASTMA48CL 30 (advise motor frame)		
10	Washer	350V400-10	Stainless Steel		
11	Motor Connection Flange	350V400-11	Cast Iron ASTMA48CL 30		
12	Holding Bolt and Washer	350V400-12	Steel		
13	Drain Plug	350V400-13	Steel		
14	Impeller Bolt	350V400-14	Stainless Steel		
15	Flush Line	350V400-15	Stainless Steel		
*16	Bearing Bushing	350V400-16	Bronze ASTMB584C87400		
*17	Pump Shaft	350V400-17	Stainless Steel		
19	Pump Shaft Key	350V400-19	Steel		
20	Casing Gasket	350V400-20	Fiber Gasket Vellumoid		

RECOMMENDED SPARES PARTS SERIES 840SC MODEL 16X16 500V355

NO	PART NAME	PART NUMBER	STANDARD MATERIAL	PART NUMBER	OPTIONAL MATERIAL
1	Volute Casing	500V355-01	Cast Iron ASTMA48CL 30		Bronze STMB584C87400
1.1	Volute Casing				Stainless Steel 304
1.2	Volute Casing				Ductile Iron 300 PSI GGG50
1.3	Volute Casing				Cast Steel ASTMA216WCB
*2.1	Impeller Wearing	500V355-02-1	Cast Iron ASTMA48CL 30		
*2.2	Impeller Wearing			500V355-02-2	Brass
*2.3	Impeller Wearing			500V355-02-3	Bronze ASTMB584C87400
*2.4	Impeller Wearing			500V355-02-4	Stainless Steel 304
3	Motor Shaft Key	500V355-03	Steel		
*4	Impeller	500V355-04-1	Cast Iron ASTMA48CL 30	500V355-04-2	Brass
4	Impeller			500V355-04-3	Bronze ASTMB584C87400
4	Impeller			500V355-04-4	Stainless Steel 304
*5	Casing Wearing	500V355-05-1	Cast Iron ASTMA48CL 30	500V355-05-2	Brass
5	Casing Wearing			500V355-05-3	Bronze ASTMB584C87400
5	Casing Wearing			500V355-05-4	Stainless Steel 18-8 Open Designation
6	Bracket	500V355-06	Cast Iron ASTMA48CL 30 (advise motor frame)		
*7	Mechanical Seal	500V355-07	Buna/Silicone Carbide w/ Stainless Steel		Client's Choice
8	Mechanical Seal Cover	500V355-08	Cast Iron ASTMA48CL 30		
*9	Split Coupling	500V355-09	Cast Iron ASTMA48CL 30 (advise motor frame)		
10	Washer	500V355-10	Stainless Steel		
11	Motor Connection Flange	500V355-11	Cast Iron ASTMA48CL 30		
12	Holding Bolt and Washer	500V355-12	Steel		
13	Drain Plug	500V355-13	Steel		
14	Impeller Bolt	500V355-14	Stainless Steel		
15	Flush Line	500V355-15	Stainless Steel		
*16	Bearing Bushing	500V355-16	Bronze ASTMB584C87400		
*17	Pump Shaft	500V355-17	Stainless Steel		
19	Pump Shaft Key	500V355-19	Steel		
20	Casing Gasket	500V355-20	Fiber Gasket Vellumoid		

RECOMMENDED SPARES PARTS SERIES 840SC MODEL 16X16 500V400

NO	PART NAME	PART NUMBER	STANDARD MATERIAL	PART NUMBER	OPTIONAL MATERIAL
1	Volute Casing	500V400-01	Cast Iron ASTMA48CL 30		Bronze STMB584C87400
1.1	Volute Casing				Stainless Steel 304
1.2	Volute Casing				Ductile Iron 300 PSI GGG50
1.3	Volute Casing				Cast Steel ASTMA216WCB
*2.1	Impeller Wearing	500V400-02-1	Cast Iron ASTMA48CL 30		
*2.2	Impeller Wearing			500V400-02-2	Brass
*2.3	Impeller Wearing			500V400-02-3	Bronze ASTMB584C87400
*2.4	Impeller Wearing			500V400-02-4	Stainless Steel 304
3	Motor Shaft Key	500V400-03	Steel		
*4	Impeller	500V400-04-1	Cast Iron ASTMA48CL 30	500V400-04-2	Brass
4	Impeller			500V400-04-3	Bronze ASTMB584C87400
4	Impeller			500V400-04-4	Stainless Steel 304
*5	Casing Wearing	500V400-05-1	Cast Iron ASTMA48CL 30	500V400-05-2	Brass
5	Casing Wearing			500V400-05-3	Bronze ASTMB584C87400
5	Casing Wearing			500V400-05-4	Stainless Steel 18-8 Open Designation
6	Bracket	500V400-06	Cast Iron ASTMA48CL 30 (advise motor frame)		
*7	Mechanical Seal	500V400-07	Buna/Silicone Carbide w/ Stainless Steel		Client's Choice
8	Mechanical Seal Cover	500V400-08	Cast Iron ASTMA48CL 30		
*9	Split Coupling	500V400-09	Cast Iron ASTMA48CL 30 (advise motor frame)		
10	Washer	500V400-10	Stainless Steel		
11	Motor Connection Flange	500V400-11	Cast Iron ASTMA48CL 30		
12	Holding Bolt and Washer	500V400-12	Steel		
13	Drain Plug	500V400-13	Steel		
14	Impeller Bolt	500V400-14	Stainless Steel		
15	Flush Line	500V400-15	Stainless Steel		
*16	Bearing Bushing	500V400-16	Bronze ASTMB584C87400		
*17	Pump Shaft	500V400-17	Stainless Steel		
19	Pump Shaft Key	500V400-19	Steel		
20	Casing Gasket	500V400-20	Fiber Gasket Vellumoid		

**LIMITED WARRANTY**

We warrant to our immediate customer and to the ultimate consumer that products of our manufacture will be free of defects in material and workmanship under normal use and service for the following time periods: when installed and maintained in accordance with our instructions. Pumps products: eight (8) years after date of invoicing. As used herein, "the ultimate consumer" is defined as the purchaser who first uses the product after its initial installation or, in the case of product designed for non-permanent installation, the first owner who used the product. It is the purchaser's or any sub-vendee's obligation to make known to the ultimate consumer the terms and conditions of this warranty. This warranty gives you specific legal rights, and there may also be other rights which vary from province/state to province/state. In the event the product is covered by the Consumer Product Warranty

(1) the duration of any implied warranty associated with the product by virtue of said law is limited to the same duration as stated herein, (2) this warranty is a LIMITED WARRANTY, and (3) no claims of any nature whatsoever shall be made against us, until the ultimate's consumer, his successor, or assigns, notifies us in writing of the defect, and delivers the product and/or defective part(s) freight prepaid to our factory or nearest authorized service station. THE SOLE AND EXCLUSIVE REMEDY FOR BREACH OF ANY AND ALL WARRANTIES WITH RESPECT TO ANY PRODUCT SHALL BE TO REPAIR AT OUR ELECTION, F.O.B. POINT OF MANUFACTURE OR AUTHORIZED PARTS REPAIR STATION, AND/OR PARTS AS PROVEN DEFECTIVE. THERE SHALL BE NO FURTHER LIABILITY, WHETHER BASED ON WARRANTY, NEGLIGENCE OR OTHERWISE. Unless stated otherwise, guarantees in the nature of performance specifications furnished in addition to the fore-going material and workmanship, warranties on a product manufactured by us, if any are subject to laboratory tests corrected for field performance. Any additional guarantees, in the nature of performance specifications must be in writing and such writing must be signed by our authorized representative.

Due to inaccuracies in field testing, if a conflict arises between the results of field testing conducted by or for user, and laboratory test corrected for field performance, the latter shall control. Components or accessories supplied by us but manufactured by others are warranted only to the extent of and by the terms and conditions of the original manufacturer's warranty.

RECOMMENDATION FOR SPECIAL APPLICATIONS OR THOSE RESULTING FROM SYSTEMS ANALYSIS AND EVALUATIONS WE CONDUCT WILL BE BASED ON OUR BEST AVAILABLE EXPERIENCE AND PUBLISHED INDUSTRY INFORMATION. SUCH RECOMMENDATIONS DO NOT CONSTITUTE A WARRANTY OF SATISFACTORY PERFORMANCE AND NO SUCH WARRANTY IS GIVEN. This warranty shall NOT apply when damage is caused by (A) improper installation, (B) improper voltage (C) lightning (D) sand or other abrasive material (E) scale or corrosion build-up due to excessive chemical content (F) rupture of mechanical seals (G) premature wear. Any modification of the original equipment will also void the warranty. We will not be responsible for loss, damage or labor cost due to interruption of service caused by defective parts. Neither will we accept charges incurred by others without our prior written approval. This warranty is void if our inspection reveals the product was in a manner inconsistent with normal industry practice and/or our specific recommendations. The purchaser is responsible for communication of all necessary information regarding the application and use of the product.

UNDER NO CIRCUMSTANCES WE WILL BE RESPONSIBLE FOR ANY OTHER DIRECT OR CONSEQUENTIAL DAMAGES, INCLUDING BUT NOT LIMITED TO LOST PROFITS, LOST INCOME, LABOUR CHARGES, DELAYS IN PRODUCTION, IDLE PRODUCTION, WHICH ARE DAMAGES CAUSED BY ANY DEFECTS IN MATERIAL AND/OR WORKMANSHIP AND/OR DELAYS IN SHIPMENT. THIS WARRANTY IS IN LIEU OF ANY OTHER EXPRESS OR IMPLIED WARRANTY, INCLUDING ANY WARRANTY OF MERCHANTABILITY OR FITNESS FOR A PARTICULAR PURPOSE. No rights extended under this warranty shall be assigned to any other person, whether by operation of law or otherwise, without our prior written approval. If any litigation is commenced between the parties hereto for the enforcement of any rights hereunder, the successful party in subject litigation shall be entitled to receive from the unsuccessful party all costs incurred in connection therewith, including a reasonable amount of attorney's fees. YOUR ACCEPTANCE OF ANY GOODS SUPPLIED BY US, OR ON OUR BEHALF, SHALL BE WITHOUT LIMITATION, CONSTITUTE ACCEPTANCE OF ALL THE TERMS AND CONDITIONS. PLEASE TAKE NOTE THAT THE WARRANTY IS ANNULLED ONCE AN INVOICE FROM FLO FAB INC REMAINS UNPAID 90 DAYS AFTER THE BILLING DATE.

Our acceptance of your order is expressly conditioned on the general terms and conditions. The contract shall not include any deviating or additional terms unless expressly agreed to in writing and signed by an officer of our company.



## ○ TERMS & CONDITIONS – SECTION 1.2

---

*Our acceptance of your order is expressly conditioned on the general terms and conditions set forth below and all terms stated on the face of this form. The contract shall not include any deviating or additional terms unless expressly agreed to in writing and signed by an officer of our company.*

**PRICES:** All prices are subject to change without notice and all shipments will be invoiced at the price in effect at the time of shipment, except when otherwise agreed to in writing by our authorized representative. Published prices are for products of our standard design and construction and any item not covered by the most recent published price list must be referred to us for special pricing. Prices do not include freight. Weights shown in price lists are approximate shipping weights. The amount of any applicable present or future tax or other government charge upon the production, sale, shipment or use of goods ordered or sold is not in the price and will be added to billing unless you provide us with an appropriate exemption certificate.

**QUOTATION:** Prices quoted by us are valid for 30 days from date of quotation unless we have otherwise specified in writing. Clerical errors on quotations are subject to our correction and such errors will not be binding.

**CANCELLATION & REVISIONS:** No purchase orders accepted and acknowledged by us may be cancelled or revised by you except with our prior written consent and upon payment of reasonable cancellation charges compensating us for all costs incurred in work done and material purchased. We reserve the right to determine what constitutes reasonable cancellation charges.

**RETURN OF EQUIPMENT:** No equipment shall be returned to us without first obtaining a written Returned Goods Authorization and shipping instruction from us. The returner must prepay the charges in full for transportation to our factory. Credit allowed for new, undamaged equipment of current standard design will be 80% of the invoiced price or current billing price, whichever is less. Equipment which has been used, however slight, will not be accepted. Authorization will not be given for return of equipment, (1) which would, in our opinion, result in an excess in the amount of stock we normally carry, (2) not invoiced within the last 3 months, or (3) which is non-standard and manufactured specifically to a buyer's specifications. For non-standard equipment not of our manufacture, the only credit allowed will be such credit as may be allowed by the manufacturer of such equipment. Equipment must be returned within 30 days of the issuance of the Returned Goods Authorization. No item with a net value of less than \$50.00 will be authorized for return. Unauthorized returns may be refused and/or returned freight collect.

**CREDIT & PAYMENT:** Payment is due as noted on our invoice. Overdue accounts are subject to a service charge. All orders are subject to approval of our credit department and we may require full or partial payment in advance. Pro rata payments shall become due as shipments are made. If the shipments are delayed by you for any cause, payments shall become due from date on which we are prepared to make shipment and storage shall be at your risk and expense. If manufacture is delayed by you for any cause, a partial payment based upon the proportion of the order completed shall become due from the date on which we are notified of the delay.

**SECURITY INTEREST:** We shall have a lien on all goods sold as security for payment on the invoice price, and upon request you shall provide and execute a financing statement showing such lien.

**DELIVERY:** We will reasonable effort to meet your delivery requirement provided you provide us, on a timely basis, all approvals, technical data, instructions and credit approval requirements needed for release of the shipment. However, all delivery and/or shipment dates are estimates only unless we have expressly guaranteed delivery of such dates in writing at your specific request. In no event shall we have any liability if delivery is delayed by strikes, labour disturbances, material shortages, plant calamities or disaster, acts of God, government actions, civil disturbance, the failure of any pre-supposed condition of the contract, withholding shipments due to credit clearance, or other interferences beyond our reasonable control, and the date of delivery shall be extended for a period of time equal to the time lost because of any such reason.

**SHIPPING:** Unless you specify in writing and we acknowledge in writing, (A) goods will be boxed or crated as we may deem proper for protection against normal handling and for domestic shipment, (B) routing and manner of shipment will be at our discretion, and may be insured at your expense. An extra charge will be made for special handling. All shipments are F.O.B. point of manufacture. Delivery of goods to the initial carrier will constitute delivery to you and all goods will be shipped at your risk. A claim for loss or damage in transit must be entered with the carrier and prosecuted by you. Acceptance of material from a common carrier constitutes a waiver of any claims against us for delay, damage or loss.

**GOVERNING LAW:** It is understood and agreed that these Terms and Condition of Sale shall be interpreted under and pursuant to the laws of the Province of Quebec; you agree that any action at law which is related to any contract of sale brought against the company shall be filed in the appropriate court located in the Province of Quebec.





